



LUSAIL DEVELOPMENT

Marafeq's Design Guidelines for the Connection of ETS(s) to the District Cooling System

Document No.: LUS-CPALL-MAQ-SPE-UT-00004

REV. NO.	DATE	DESCRIPTION	PREPARED BY	CHECKED BY	APPROVED BY
1	09-08-2011		Anders Tvarne	Abdullah Abushaikha	D. Reed Phillips
2	12-04-2012		Muhammad Ali	Abdullah Abushaikha	D. Reed Phillips
3	22-04-2014		Muhammad Ali / Uday Diwakar	Abdullah Abushaikha	D. Reed Phillips
4	10-11-2014	Table 3.1, 4.2 and 5.1 revised.	Muhammad Ali / Uday Diwakar	Vinod Kesavan	D. Reed Phillips

CONTENTS

1	INTRODUCTION	5
1.1	The District Cooling System	5
1.2	General	5
1.3	Definitions	6
2	THE CUSTOMER SCOPE OF WORK	8
2.1	ETS Plant Room for District Cooling, general	8
2.2	Primary Service Line	8
2.3	Primary Interconnecting Pipes	8
2.4	ETS	8
2.5	CUSTOMER Internal Chilled Water System	8
2.6	Pipe Cleaning and Commissioning	9
2.7	Pressure Tests, Inspections and Quality Control	9
2.8	Procedures for Connection to District Cooling	9
3	TECHNICAL REQUIREMENTS AND RECOMMENDATIONS	10
3.1	Design Criteria	11
3.2	Norms and Standards	11
3.3	ETS Plant Room for District Cooling, Particular Requirements	12
3.4	ETS Installation and Component Requirements	12
3.5	Secondary Side Chilled Water System, Pumps and Operation	13
3.6	Secondary Side Air Handling-, Fan Coil- and Terminal Units	13
3.7	Electrical Power Supply	14
4	SPACE AND EQUIPMENT	14
4.1	Location and Sizes	14
4.2	ETS Equipment Requirements	14
4.3	ETS Environment and Conditions	15

4.3.1	ETS Room Conditions	15
4.3.2	Room Ventilation	15
4.3.3	Primary Interconnecting Pipes Protection	15
4.3.4	Make-up Water and Chemical Water Treatment on the Secondary Systems	15
4.3.5	Water Quality for Primary and Secondary Systems	16
4.3.6	Plumbing / Drainage	16
4.3.7	Power Outlet / Lighting	16
4.3.8	Communication	16
5	ENERGY METERS	17
5.1	General	17
6	DISTRICT COOLING SYSTEM COMPONENTS AND MATERIALS DESCRIPTIONS	18
6.1	Pipes and Fittings	19
6.2	Components	19
6.2.1	Pipes	19
6.3	Valves	19
6.3.1	Isolation Valves	19
6.3.2	CIP Connection	20
6.3.3	Safety Relief Valves	20
6.4	Strainers	20
6.5	Indicators	20
6.5.1	Pressure Indicators	20
6.5.2	Temperature Indicators	21
6.6	Heat Exchanger	21
6.7	PLC System	21
6.8	Venting Valves and Drain Valves	21
7	INSTALLATION	22
7.1	Jointing	22

7.2	Insulation	22
7.3	Tagging	22
7.4	CHANGES TO THE SYSTEM	23
8	APPENDICES	23
Appendix 1:	Application for “Design Conformance Certificate”	
Appendix 2:	ETS Examination summary for “ETS Conformance Certificate”	
Appendix 3.1:	PI&D - Schematic of ETS installation for Single Heat Exchanger	
Appendix 3.2:	PI&D - Schematic of ETS installation for Multiple Heat Exchanger	
Appendix 4.1:	Compliance statement for Plate Heat Exchanger	
Appendix 4.2:	Compliance statement for Pressure Independent Control Valve	
Appendix 4.3:	Compliance Statement for primary side isolation Valve (Ball Valve)	
Appendix 5 :	PLC System	
Appendix 6 :	Bulk Meter (energy meter) Guidelines	
Appendix 7.1:	Compliance statement: Method statement for Installation, Testing and Commissioning of equipment inside ETS (Primary side)	
Appendix 7.2:	Compliance statement: Method statement for Hydro static test (Primary side)	
Appendix 7.3:	Compliance statement: Method statement for Flushing/Pipe conditioning (Primary side)	

1 INTRODUCTION

1.1 The District Cooling System

The ETS (Energy Transfer Station) in Lusail development is the CUSTOMER's part of the District Cooling System operated by MARAFEQ. This "Marafeq's Design Guidelines for the connection of ETS (s) to the District Cooling System" (Document No LUS-CPAA-MAQ-SPE-UT-004) is to address the general principles and technical requirement to be applied for the design and construction of ETS. Since the ETS is a part of the District Cooling system it must be built, maintained and operated in such a way that it complies with the requirements of this document.

District Cooling is an environmental friendly technology for producing and distributing refrigeration to real estate. For an efficient system all included parts of the supply chain need to function efficient. A District Cooling system consist of centralized production plant(s) a distribution network and ETS's. MARAFEQ here describes requirements for the ETS in order to optimize the DC system function.

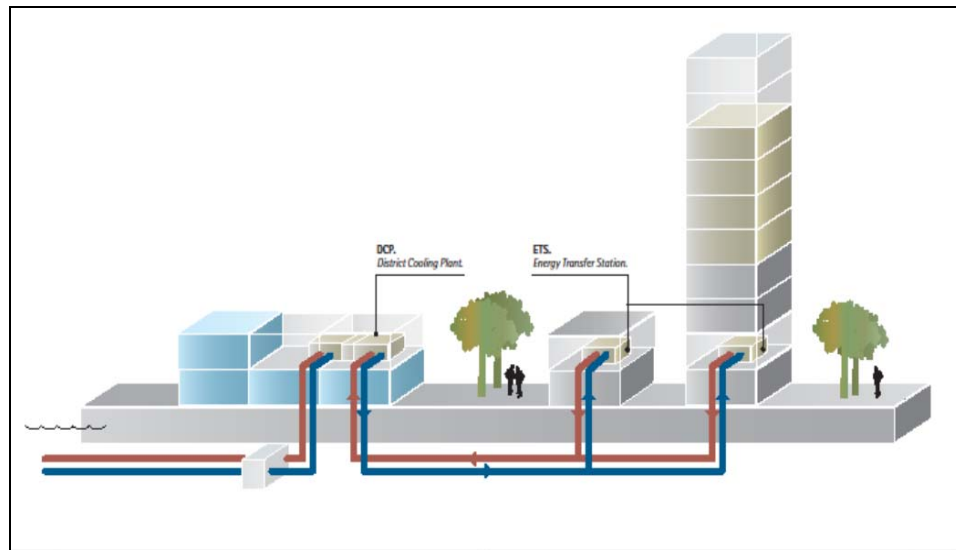

Figure 1: District cooling system – general schematics

1.2 General

This document describes the Technical Requirements for connecting to MARAFEQ District Cooling Systems. The document should be used for planning, preparation of specifications and procurement during initial design phases in advance of the formal agreement between MARAFEQ and developers/c/end-users.

All technical requirements that applies for connecting to the District Cooling Network are specified in this document.

This document replaces the previously provisional MARAFEQ “Booklet 1” to instead be used as a design guideline and for technical requirements of the ETS. Any description statements in the provisional Booklet 1, will no longer apply.

1.3 Definitions

Client	The master developer - Lusail Real Estate Development Company (LREDC) or its appointed representative.
Contractor	The organization or its appointed representative appointed by Customer, responsible for execution of the works of ETS.
Customer	The owner / sub-developer in-charge of the building.
DC,DCP	District Cooling, District Cooling Plant
Engineer	Marafeq’s supervision engineer or its appointed representative.
Energy Meter	As described in clause 5
ETS	The Energy Transfer Station (ETS) is the point where the energy from the building is transferred to the district cooling system. An ETS consist of pipes, valves, filter(s), metering and heat exchanger(s).
MARAFEQ	The utility company which provides District Cooling, Gas Supply and Waste Management services in Lusail city.
Mega-Developer	The owner of the district.
PHE or HEX	Plate Heat Exchanger, component separating the primary water system from the secondary water system. Definition used can sometimes also be for Heat Exchanger (HEX).
PLC	PLC – (Programmable Logic Controller) a programmable microprocessor used to automate monitoring and control of ETS.
Point of Delivery	The point of delivery is defined as where MARAFEQ scope of works for the primary chilled water supply ends, whereas: <ul style="list-style-type: none"> - 1m outside from the utility tunnel. - 1m into the plot “set-back” for buildings connected by directly buried pipes. For above both cases MARAFEQ will install isolation valves, in the branch pipe to the building from main network piping system.
Point of Return	The point of return is defined as where MARAFEQ scope of works for the primary chilled water return starts, whereas: <ul style="list-style-type: none"> - 1m outside from the utility tunnel. - 1m into the plot “set-back” for buildings connected by directly buried pipes. For both cases above MARAFEQ will install extra isolation valves, in the outside main pipe system.
Primary	“Primary” refers to the («Supply» and «Return») pipe network circulating chilled water produced in District Cooling Plants through the MARAFEQ distribution network.
Primary Inter-connecting Pipes	The Primary Interconnecting Pipes run from the main isolation valves inside the building wall to the ETS PHE(s) located in the ETS Plant Room.
Primary Service Line	The Primary Service Line run from the “Points of Delivery and return” to the individual building interior wall. A set of isolation valves shall be installed where the service line penetrates the building wall.
Secondary	The “Secondary” are the CUSTOMER’s cooling water circuits («Supply» and «Return») on the building side systems of the heat exchangers.
Pre- fabricated ETS	These ETS are pre-fabricated in the factory, installed and tested. They are mounted on a steel frame, and are possible to transport assembled, which makes installation of a high quality and with a minimum time on site. However conditions and restrictions on transportation openings may lead to that the ETS must be disassembled, shipped and reassembled on site. The ETS can therefore be built in modules or with assembly parts on site. These ETS can be designed with 1, 2, 3 or more PHE units, depending on the scope of the cooling load demand and desired DC delivery availability.

Trial Operation	Testing period of the ETS functions before commercial operations, where Marafeq performs test runs and checking the ETS performance.
Vendor	Any invited companies being fully eligible to submit the Tender. The successful Vendor will be the contractor/Supplier.

2 THE CUSTOMER SCOPE OF WORK

MARAFEQ reserves the right to supervise, inspect and approve the installation of the ETS and primary side piping, i.e. the equipment that will be operated by MARAFEQ.

2.1 ETS Plant Room for District Cooling, general

The CUSTOMER should provide a suitable space for the installation of the District Cooling system ETS equipment, the “ETS Plant Room for District Cooling”. This should include space for the service lines, interconnecting pipes as well as floor drain and fresh water piping.

MARAFEQ shall have full and direct access to the ETS Plant Room for District Cooling 24/7.

2.2 Primary Service Line

The CUSTOMER’s scope of works including the primary pipes from the “Point of Delivery” and “Point of Return” to the location of the main isolation valves located inside the building’s wall penetration. The pipes shall be of industrial standard of District Cooling and by the quality approved by MARAFEQ.

2.3 Primary Interconnecting Pipes

The CUSTOMER’s scope of works includes the interconnecting primary pipes from the main isolation valves (refer 2.2 above) inside the wall penetration to the connection flanges of the ETS PHE located in the ETS Plant Room for District Cooling. The pipes shall be of industrial standard of District Cooling systems and by the quality approved by MARAFEQ.

2.4 ETS

The CUSTOMER’s scope of works includes complete ETS(s) as described in this “MARAFEQ Technical Requirements for the connection of ETS(s) to the District Cooling System” specifications.

The ETS(s) belongs to the Customer, and has no rotating & moving parts. District Cooling will therefore, compared to Chillers located in each building, have no or very limited disturbing noise or vibrations.

The ETS equipment requirements and the scope of work are detailed in Table 4.2 of this document.

2.5 CUSTOMER Internal Chilled Water System

The CUSTOMER or their representative shall design, provide, operate and maintain the secondary side chilled water system in accordance with the technical requirements.

Variable speed chilled water pumps and two way control valves shall be used for varying the CUSTOMER’s chilled water flow.

2.6 Pipe Cleaning and Commissioning

The CUSTOMER shall prior to the commissioning perform a complete and thorough pipe flushing, cleaning and passivation of the primary side and flushing, pipe cleaning, passivation and chemical water treatment of the secondary side chilled water piping network, so that at the time of connection to the ETS PHE, the CUSTOMER's piping system is full of clean water and is clear from unwanted debris and particles.

Submit method statement for testing, pipe flushing, cleaning and passivation of primary side piping system at least 4 weeks prior to the proposed starting of flushing and cleaning. Only after the method statement is reviewed and No Objection is issued by Marafiq, the process of flushing and cleaning shall be started.

After MARAFEQ approves the water quality analysis, the primary side may be supplied with chilled water from District Cooling system, subject to the terms and conditions in 'Cooling Services Agreement'.

CUSTOMER shall be responsible to maintain approved passivation water quality until supply of chilled water.

2.7 Pressure Tests, Inspections and Quality Control

The CUSTOMER shall, prior to MARAFEQ taking over operational responsibility for the ETS and the primary side piping, get MARAFEQ's approval for the works done by the CUSTOMER.

This includes all the CUSTOMERS activities regarding cleaning and commissioning as mentioned in 2.6, but also necessary inspections, x-ray, quality control and pressure tests. This approval must be obtained before MARAFEQ will connect to the District Cooling Network and start commissioning/test run followed by commercial operation.

2.8 Procedures for Connection to District Cooling

To connect to the MARAFEQ district cooling system involves a connection approval procedure. The connection procedure starts with the CUSTOMER contacts MARAFEQ for an introduction meeting. A Cooling Services Agreement (CSA) shall be negotiated and signed.

The CUSTOMER shall present estimations of the cooling demands. MARAFEQ will review the estimated calculated cooling demand and advise the CUSTOMER if required.

For the installations of the DC connection and building cooling systems the requirements in the "MARAFEQ Technical Requirements for connection to the District Cooling system" must be followed.

MARAFEQ shall approve the location of the ETS room. The actual location of connection point from the primary district cooling pipe system (point of supply and return) will also be decided by MARAFEQ.

The approval procedures for the installation involves that the CUSTOMER shall present; Layouts of the ETS Room for District Cooling, Pre-design of the building cooling systems and Template with information for the application of "Design Conformance Certificate". See *Appendix 1*. The detailed Utility Application Procedure for DC system is explained in the Marafiq Document no: LUS-CPALL-MAQ-PRC-UT-40040.

When the "Design Conformance Certificate" for the ETS and installation of DC connection is approved, the installation work may then start.

When the ETS installation is ready, a final inspection shall be performed. MARAFEQ shall be invited to the final inspection, performed by MARAFEQ. When the final inspection is approved, MARAFEQ will issue an “ETS Conformance Certificate”. Refer ‘Cooling Services Agreement’ for the requirements of issuing the “ETS Conformance Certificate”.

Application for “ETS Conformance Certificate” is attached in *Appendix 2*. Start-up for cooling operations will be initiated when MARAFEQ opens the chilled water valves connecting the building to the DC network.

3 TECHNICAL REQUIREMENTS AND RECOMMENDATIONS

MARAFEQ reserves the right to review and approve the design of the ETS and secondary side of the cooling system to make sure it will work and operate together with the District Cooling Network.

The schematic of an ETS installation and the components are shown in the Appendix 3.1 and 3.2.

MARAFEQ recommendations:

- For high quality and short installation time on site MARAFEQ recommend the use of pre-fabricated standardized ETS.
- The installation can depend on needed cooling demand be divided up with 1, 2 or 3 standard PHE. This applies for standard ETS installations for subscribed cooling demands between 70 and 2900 TR.
- Cooling demand over 2900 TR will need special attention, since standard concept normally cannot be used.
- When high availability of cooling is of special importance at least two 50% PHE is recommended instead of only one 100% PHE. Higher availability might be requested for Commercial use than for Residential buildings.
- Each PHE should have a 20% extra space for capacity expansion possibility on the frame.
- Redundant (standby) PHE is generally not required. However, Sub developer can decide the redundancy requirement based on their requirement.

3.1 Design Criteria

Table 3.1: Design Criteria

Design pressure, primary side	bar (g)	16
Test pressure, primary side	bar (g)	23
Maximum pressure difference over ETS (ΔP) (Note 1)	bar	10 bar
Design ambient temperature for installation, primary side	°C	50
Maximum allowed pressure drop at nominal flow and subscribed load between points of delivery and return. (NOTE 2)	kPa	150
Maximum HEX pressure drop at design flow	kPa	65
Cooling Capacity:	TR	To be Provided by Customer
Available differential pressure. (NOTE 3)	kPa	To be provided by Marafeq
Supply chilled water temperature, DC Side (t_{DCS}):	°C	+5.0
Return chilled water temperature, DC Side (t_{DCR}):	°C	+14
Supply cooling water temperature, CUSTOMER Side (t_{CCS}): (Note 4):	°C	+6.2
Return cooling water temperature, CUSTOMER Side (t_{CCR}): (Note 4):	°C	+15.2
Maximum chilled water flow per ton cooling load (design):	l/s	0.095

NOTE 1): Customer should select PICV to meet the above design criteria. Customer may install double regulating valves (DRV) to reduce the system working pressure to within the capabilities of the PICV.

NOTE 2): The maximum pressure drop shall be used by the Customer when designing connecting pipes and components assuming the control valves to be fully open.

NOTE 3) The actual available differential pressure for the ETS depends on the location in the District Cooling Network and may also change over time as the District Cooling Network develops. To be provided by MARAFEQ.

Note 4) Indicative values only. Customer to design the chilled water supply and return temperatures on secondary side based on the building side HVAC design with Delta T of 9 deg C (ΔT 9 °C).

Other Notes:

- It is critical that all air handling units, fan coil units etc. are designed for the stated Customer Side temperatures in the table above to provide at least a +14°C primary return temperature. This means that the maximum flow required for 1 ton of cooling load is 0.095 l/s (1.5 USGPM). If the building cannot meet this requirement, MARAFEQ cannot guarantee a supply chilled water temperature mentioned on the Customer Side at peak load conditions.
- Pipe pressure drop calculations and pumps flow-head diagrams and differential pressure set at circuit end of the Customer's chilled water circuit (secondary side) are to be coordinated with MARAFEQ during design stage.

3.2 Norms and Standards

These standards must be used for the primary side, but are recommended for the secondary side as well.

When an edition date is not indicated for a code or standard, the latest edition in force at the time of contract award shall apply.

- EN 253: 2009 District heating pipes – Pipes (applicable parts)
- EN 448: 2009 District heating pipes – Fittings (applicable parts)
- EN 489: 2009 District heating pipes – Jointing (applicable parts)
- EN 13 480: 2011 Metallic industrial piping
- EN 13 941: 2009 Design and installation of pre-insulated pipes
- 97/23/EG Pressure Equipment Directive (PED)
- Directive 2006/42/EC on machinery
- Kahramaa Regulations for the Installation of Electrical Wiring, Electrical Equipment and Air Conditioning Equipment (applicable parts)
- QCS Qatar Construction Specifications
- QCD Qatar Civil Defense
- Local standards All applicable standards, specifications and regulations issued and/or referred to by Authorities, City Council, Civil Services department or other parties

3.3 ETS Plant Room for District Cooling, Particular Requirements

Whether the “ETS Plant Room for District Cooling” is in a separate building or part of an existing or new structure there are several requirements to consider.

MARAFEQ Requirements:

- The ETS Plant Room for District Cooling shall be located not higher than 5 meters above ground level and have sufficient ceiling height below any obstructions such as beams, drop slab etc. (recommended height is minimum 4 m).
- The transport ways to the ETS plant room, including all doors shall allow access for the heat exchanger(s) without any need for disassembling.
- Ventilation air into the room shall be filtered and cooled as required to meet the operating requirements/limits for all ETS equipment or to a max temperature of $28\pm 2^{\circ}\text{C}$ and 50-60% RH.
- ETS room lighting shall consist of overhead white fluorescent type lighting (not less than 150 Lux).
- Fire detection and alarm system shall be provided.
- Lockable, insulated security doors should be provided.
- The space should be provided with all necessary overhead and under-floor plumbing including service water piping and floor drains near each PHE and for general purpose.

MARAFEQ Recommendations:

- The room should be acoustically treated so the noise level meets the CUSTOMER's expectations.
- The room should have finished painted walls and oil resistant non-slip finished floor.

3.4 ETS Installation and Component Requirements

MARAFEQ Requirements:

- Primary system piping, valves and equipment must be all welded. All materials/equipment shall be of industrial standard. No flanges are allowed except for the heat exchanger, flanged spool piece, strainer, control valve(s) and flow meter. The flanges used shall be weld neck type.
- Primary system piping and valves must be thermally insulated in accordance with clause 7.3.

- Isolation valves must be provided in the supply and return pipe around the heat exchanger(s) to allow for maintenance and cleaning.
- Safety relief valve located between the isolation valves at each heat exchanger in order to prevent overpressure during shut downs.
- A full port ball valve (DN50) with hose connection and cap for manual air vent on the top connection side of the heat exchanger as shown on the schematic. Also a ball valve (DN50) with hose connection and cap for drainage at the bottom connection of the heat exchanger. End plugs can be removed from each end to allow connection to clean water so the heat exchanger can be flushed and cleaned while the isolation valves are closed.
- Installation of threadolets on both the primary side and the secondary side, to be used for temperature transmitters (TT).
- MARAFEQ requires the usage of pressure independent control valves for highest possible ΔT , minimum energy use and reduced labour cost. For highest possible availability one control valve for each PHE is recommended
- A strainer is required at the inlet of the heat exchanger(s) with a differential pressure gauge arranged so that it is possible to measure the pressure upstream / downstream the strainer and in the supply pipe as per attached PI&D schematic, see *Appendix 3*.

3.5 Secondary Side Chilled Water System, Pumps and Operation

MARAFEQ Requirements:

- One set of variable speed pumps for internal chilled water distribution for each ETS, with an expansion tank complete with a safety relief valve for each closed loop.
- Variable speed pumps shall be controlled by utilizing at least two industrial grade pressure differential transmitters (PDT) across the two most hydraulically remote terminal units in each building as shown in *Appendix 3*. Exact location shall be coordinated with MARAFEQ.
- Variable speed pumps shall be equipped with at least one pressure switch in the supply line that will stop the pumps at max design pressure in case of a valve closure and/or a failure with the VFDs (Variable Frequency Drive). The pressure switch should be hardwired to the pumps and not through the ordinary control system.

MARAFEQ recommendations:

- As indicated on PI&D *Appendix 3* it is recommended for low flow control for VFD pumps to add a 2-way control bypass valve around the pump. The 2-way control bypass valve shall correspond to the minimum flow requirement of one pump.

3.6 Secondary Side Air Handling-, Fan Coil- and Terminal Units

MARAFEQ Requirements:

- Use only two way control valves for all air handling units and fan coil units. The valve must be capable of controlling flow through full range of expected turn-down and through full range of expected ΔP across the valve.
- Test, adjust and balance the hydraulic system to make sure that the chilled water requirement of each fan coil unit and air handling unit is met, preferably the Testing, Adjusting and Balancing (TAB) shall be carried out by a specialized third party commissioning firm.

MARAFEQ recommendations:

- MARAFEQ strongly recommends the usage of pressure independent control valves for highest possible ΔT , minimum energy use and reduced labour cost.
- If pressure independent control valves are being used, no manual balancing valves are required. Otherwise all air handling units, fan coils units and main branches shall have

manual balancing valves with self-sealing test point used for chilled water flow measurement as required during balancing and commissioning.

3.7 Electrical Power Supply

The CUSTOMER shall provide a dedicated Distribution Board in the ETS room. The Distribution Board shall be 6 way, single phase 240V, 50Hz with 40A incomer and 4 No. 10A MCBs to feed the Energy Meter and PLC. The Distribution Board shall be fed from the essential side of the MV panel and UPS.

4 SPACE AND EQUIPMENT

4.1 Location and Sizes

Consideration should be given to transportations and access so that repair, replacement, etc. easily and rapidly can be made. If the building owner does not allow free passage to the building a separate access door from outside must be arranged. Space requirements should be determined by the service possibilities.

The ETS room shall be available for MARAFEQ for control and manual reading of metering equipment.

4.2 ETS Equipment Requirements

Scope of equipment is explained in the following table.

C = Provided by CUSTOMER (or his appointed Designer or Contractor)
M= Provided by MARAFEQ

Table 4.2: ETS scope of equipment

Space for ETS	Should be included CUSTOMERs scope	Provided by MARAFEQ
Lighting	C	
Electrical supply	C	
Meter place	C	
Floor drain	C	
Flushing possibility	C	
ETS primary side		
Isolation Valves	C	
Strainer(s)	C	
Pressure gauges	C	
Temperature indicators	C	
Heat exchanger(s)	C	
Control valve(s) DC	C	
Differential pressure transmitter (if necessary, connection shall be included)		M(note-1)
Dummy pipe / flow sensors	C	
Metering equipment		M(note-1)
Venting valves	C	
Drain valves	C	
Clean in place (CIP) connections	C	
ETS secondary side		
Circulation pumps	C	

Expansion vessel	C	
Temperature transmitters	C	
Pressure indicators and transmitters	C	
Safety valve	C	
Filling valve	C	
Strainer(s)	C	
Drain valves	C	
CIP connections	C	

Note1: See also table 5.1

4.3 ETS Environment and Conditions

4.3.1 ETS Room Conditions

The CUSTOMER shall maintain the following ambient conditions in the ETS room:

Temperature:	28°C ±2°C
Relative humidity:	HR 50-60%

4.3.2 Room Ventilation

Mechanical ventilation/Air-conditioning of the ETS room shall provide continuous refreshment of the air, to prevent condensation that will eventually cause corrosion on equipment.

Ventilation air into the room shall be filtered and cooled as required to meet the operating requirements/limits for all ETS equipment. See conditions 4.3.1. Minimum fresh air ventilation shall be as per ASHRAE std. 62.1, good engineering practice and to keep a positive pressure level in the ETS room.

4.3.3 Primary Interconnecting Pipes Protection

The network shall be protected from the weather, water splashes, shocks and in general any risk of degradation along the path of the primary network in rooms through which it passes.

Pipe protectors should be added to any piping within garbage rooms, parking ramps or other highly trafficked areas where piping could get damaged.

4.3.4 Make-up Water and Chemical Water Treatment on the Secondary Systems

The CUSTOMER will be responsible for filling the internal chilled water system along with providing break tanks of suitable capacities and with pressurization units which shall be incorporated to prevent back flow and positive supply into the system.

A DN20 potable water supply shall be provided with a ball valve and a water line should be stubbed to the space with a hose bib connection for cleaning of the PHE when disassembled.

The chilled water is considered a non-potable water source. Consequently, the local water authority will require a backflow preventer to be installed on all city water lines connected to the building chilled water system.

Water treatment system shall include manual feed chemicals dosing pot with necessary rust inhibitors and biocides quantity necessary for testing, commissioning and operation. A specialized professional company shall handle the water treatment system.

The CUSTOMER shall provide an analysis of the physicochemical characteristics of the water in his secondary circuit, before the Commercial Operation of his ETS.

The MARAFEQ Operation service reserves the right to draw off water samples from the secondary circuit and analyses it at any time.

The CUSTOMER shall pay for maintenance and water sampling costs if his water treatment is not conforming to the specifications mentioned above. These characteristics may be maintained by conditioning the secondary network.

4.3.5 Water Quality for Primary and Secondary Systems

For the operation of the district cooling systems it is important to maintain a high water quality. The system operation is dependent on the heat transfer between the primary and the secondary. A clean PHE must be secured. It is important that the CUSTOMER secure a minimum water quality in the secondary side systems in order to reduce impact of fouling and also to reduce corrosion. A fouled PHE surface will lead to reduced capacity. The following characteristics should then be followed:

Chemical Parameter	Limits after addition of final chemical
pH	9 to 10.5
Total Iron (mg/L)	<1.0
Nitrite (NO ₂) (ppm)	>800
Conductivity (μS/cm)	<3000
Suspended Solids (mg/L)	<10
Total Dissolved Solids (mg/L)	<2000
Total Hardness (ppm)	<100
M-Alkalinity (ppm)	<250

4.3.6 Plumbing / Drainage

A floor drain or a sump (with lifting pump) shall be provided to evacuate drain water, washing water and various drips. Open gutters with grated covers are preferred.

Vents shall be provided in high points and drains in low points with outlet conduits located along the path of the primary pipes as far as the special connection to the sewer at the penetration point into the building.

It must be possible to discharge water effluents to nearby drains, after specific maintenance operations. The details of each should be specified on construction drawings and on detail drawings.

Venting and drain points should remain accessible for network maintenance.

4.3.7 Power Outlet / Lighting

The CUSTOMER shall provide an additional and separated from the ETS 240V single phase + earth power outlet protected by a 16A circuit breaker (D curve), necessary for maintenance operations.

The room must be sufficiently well illuminated with overhead white florescent type lighting, so that maintenance operations can be carried out under good safety conditions.

4.3.8 Communication

- Ethernet TCP:

CAT6 with RJ45 cable shall be laid by the CUSTOMER from ETS PLC panel up to Ooredoo's telecom room, the cable shall not have any spliced or joints and cable length shall be less than 90 meters.

If distance between ETS PLC to the telecom room exceeds 90 meters, in this case CUSTOMER needs to provide fiber optic cable (Single mode), media convertor etc. for seamless redundant (2 x 2Fiber) communication with DCP up to ETS telecom room.

CUSTOMER shall submit technical data sheet, wiring diagram, schematic diagram manual etc. for MARAFEQ's approval.

CUSTOMER shall assist to MARAFEQ's DCP contractor for integration of the ETS to DCP.

- **Wireless :**

CUSTOMER shall supply and install wireless equipment and its accessories in the ETS. This is required for integration of the ETS to DCP till fiber optic communication (Telecom room) is operational.

CUSTOMER shall provide wireless communication proposal with technical detail for MARAFEQ's review and approval.

CUSTOMER shall assist to MARAFEQ's DCP contractor for integration of the ETS to DCP.

5 ENERGY METERS

5.1 General

The metering equipment includes the supply and return pipe temperature sensor and the supply pipe flow meter. Marafeq shall supply ETS energy metering equipment that will be used for billing purpose. The detailed guidelines for the installation and wiring of metering system is included as Appendix-6 of this document.

MARAFEQ will supervise the installation and wiring of energy meters.

The CUSTOMER may provide a dummy (spool piece) for the flow meter and install when appropriate.

Table 5.1: ETS control and instrument

ETS Control and Instrument					
Item	Description	Supply By	Installed By	Cable Trays with Cable	Connection By
1	Threadolets for Instruments	C	C	N/A	N/A
2	Thermo wells for temperature transmitters	M	C	N/A	N/A
3	Instruments (PDT/TT) (refer appendix 3.1 and 3.2)	M	C	C	M
4	Flow Meter (FM)	M	C	C	M

5	Energy Meter	M	C	C	M
6	Control Valve	C	C	C	C
7	PLC including panel	C	C	C	C
8	Wiring for controls	C	C	N/A	C
9	Instruments (Pressure Switch) PS	C	C	C	C

C = CUSTOMER or his appointed Designer or Contractor; M = MARAFEQ

The metering devices should be connected to a PLC system for metering values transmission.

MARAFEQ Requirements:

The CUSTOMER shall provide all control wiring linking between the CUSTOMERs building automation system (BAS) to PLC in the ETS.

The data points used to calculate billing are:

- District Cooling Supply Temperature
- District Cooling Return Temperature
- District Cooling Flow

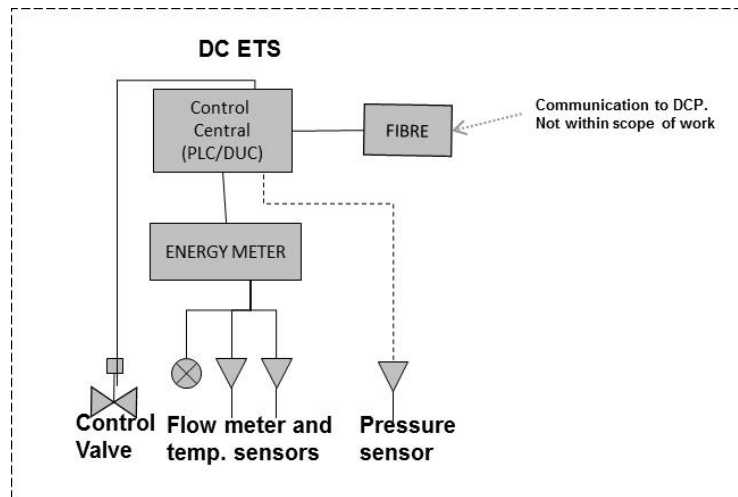

Figure 3: Data points for metering and billing purposes

Outputs will be powered by the PLC and shall be 24 VDC sinking at the CUSTOMER'S BAS. Connected metering devices must not be disconnected by anyone other than MARAFEQ staff.

6 DISTRICT COOLING SYSTEM COMPONENTS AND MATERIALS DESCRIPTIONS

Components and fittings shall be of same materials and have at least the pressure class required in the actual system. Suitable materials are steel and stainless steel. Connections including any gaskets shall meet requirements of the applicable ANSI/ASME/EN standards

and shall be rated for the system pressure and temperatures. The components must be installed in a manner so maintenance and replacement can be easily done. Connection to the mains shall be welded / brazed. Components of the ETS should be of the same material to avoid galvanic corrosion.

6.1 Pipes and Fittings

ETS that are connected should be executed so that the district cooling side piping with associated parts must have robustness. This means that the jointing method, couplings, sealing materials and fittings must meet the requirement of tightness and mechanical stress. Couplings gaskets shall have a center support so that the whole sealing surface will be covered by the gasket.

6.2 Components

Components for the primary district cooling side should be of the following materials with at least the quality defined for each material type in:

- Pressure vessel steel P295 GH or corresponding
- Stainless steel AISI 316 or corresponding

6.2.1 Pipes

For the directly buried piping and piping inside valve chamber pre-insulated bonded pipe system shall be used. Pre-insulated pipe system shall be assembled carbon steel service pipe, polyurethane thermal insulation and outer casing of high density polyethylene (HDPE). The pre-insulated bonded piping shall comply with standard EN 253 and pre-insulated fittings shall comply with EN 448 as minimum. (Valves inside chamber shall be pre-insulated.)

For the piping exposed to view field insulated pipe system may be used. The service carbon steel pipe shall conform to dimensions in accordance with DIN 2458 and steel quality P235GH in accordance with standard EN10216-2, EN10217-2 and 10217-5.

Elbows, reducers, tees and other fittings shall comply with standard EN10253-2 type B.

Seamless steel tubes in accordance with EN10216-2 shall be used for dimensions up to DN350.

Welded steel tubes in accordance with EN10217-2 (ERW) or EN10217-5 (SAW) shall be used from dimension DN400 and larger.

As an alternative to above standard, for above ground piping, standard weight, carbon steel, ASTM A53 or A106, Grade B ERW or seamless bevelled ends pipe can be used.

6.3 Valves

6.3.1 Isolation Valves

Main isolation valves shall be located directly inside the building as close as possible to the walls. Connection to the district cooling network should be by welding.

Isolation valves must be provided in the supply and return pipe around the heat exchanger(s) to allow for maintenance and cleaning.

All isolating valves shall be of type welded ball valves. Caution is needed so that the seals in the valves will not be damaged during the welding process.

All valves shall be easily accessible and tagged.

Compliance statement for the ball valve (appendix 4.3) shall be furnished along with material submittal for Marafiq acceptance.

6.3.2 CIP Connection

In order to make CIP (Cleaning in Place) of PHE plates possible, the ETS shall have connections installed. CIP is done without dismantling the PHE.

Two ball valves (DN50) for manual air vent and drain shall be provided for each heat exchanger as shown in the P&ID schematic, *Appendix 3*. These connections will also be used for future chemical injection and periodic flushing (CIP) of each heat exchanger while the isolation valves are closed.

- Provide hose connection and cap for each valve (air vent and drain).
- Body, disc and seat rated for a zero leakage shut off at pressure class not less than the heat exchanger(s) design pressure.
- Provide lever handle with metallic extended stem for insulation.

In order to save CIP chemicals, the water volume shall be reduced to a minimum. For this the isolating valves should be located closely to the PHE.

6.3.3 Safety Relief Valves

A safety relief valve shall be located between the isolation valves at each heat exchanger in order to prevent overpressure during shut downs. The valve shall be sized for thermal expansion at design load conditions and the set pressure should be consistent with the pressure class of the heat exchanger. The customer shall submit calculations and sizing information to MARAFIQ for approval.

- Direct spring loaded type (proportional flow).
- Lever operated, with non-adjustable factory set discharge pressure.

6.4 Strainers

A strainer is required at the inlet of the heat exchanger(s) to protect the heat exchange and control valves from any suspended particles and debris. The strainer element shall allow for cleaning without being dismantled. The connections shall be flanged or welded.

- Strainer shall be Y-pattern with blow off drain valve.
- Screen shall be made of stainless steel with max perforation mesh size 0.6 – 0.8 mm.
- Screen shall be accessed by way of threaded or bolted cover.

6.5 Indicators

6.5.1 Pressure indicators

Pressure Gauge for manual reading of the primary side pressure should be included. The scale should be from 0-25 bar.

Industrial grade pressure gauge shall be provided and arranged so that it is possible to measure the pressure upstream/downstream of the strainer plus in the supply pipe.

- The pressure gauge shall be bourdon tube type, phenolic or stainless steel case with plastic lens, black letters on white surface, solid front and blow out back style.
- Stainless steel movement and wetted parts
- Gauges dial should be 100 mm diameter

6.5.2 Temperature indicators

In case of more than one heat exchanger required for a single ETS, industrial grade thermometers must be provided in the supply and return line of each heat exchanger

- Thermometers shall be Bi-metal type thermometers with 125mm diameter stainless steel dial and shatter proof glass, black letters on white surface, external pointer adjustment and rear angle adjustable with connection to thermo well.
- Thermo wells shall be 316 stainless steel bar stock construction, step type.
- The Thermo well shall protrude 1/2 pipe diameter inside the pipe and lagging extension suitable for the insulated pipe.

6.6 Heat Exchanger

The material of the Plate Heat Exchangers (PHE) must withstand both systems liquid media. Nameplate should be visible and readable. For chemical cleaning, the manufacturer shall be consulted. PHE shall be located on a drip tray.

PHE shall be designed, built and marked in full compliance to AHRI-400 Liquid-to-Liquid Plate Heat Exchangers with ZERO tolerances.

Manufacturers of heat exchangers should be able to show that heat exchangers meet the test program described in the standard EN 1148 or equal. The control also includes the manufacturer's data design programs are consistent with product performance. Always use the latest version of the design program.

Compliance statement for Plate Heat Exchanger (appendix 4.1) shall be furnished along with material submittal for Marafeq acceptance.

6.7 PLC System

PLC system shall be used for Control, Monitoring and data acquisition at the Energy Transfer station. Supply and installation of PLC system is described in **Annexure 5** of this document. Compliance statement for PLC shall be furnished along with material submittal for Marafeq acceptance.

6.8 Venting Valves and Drain Valves

Venting valve DN 15 with bleeds should be installed on the highest point in the direction of flow of the DC pipes for manual extraction of air in the system. The bleeds should be fitted with valve end cap 400 mm above floor.

Drain valve DN 15 with bleeds should be installed at the lowest point of the pipes. The bleeds should be fitted with end cap.

7 INSTALLATION

7.1 Connection with DC Network

The Infrastructure DC tie-in point is extended by one (1) meter inside the plot boundary. The tie-in point information (co-ordinates and levels) shall be obtained from Lusail and to be verified at site by the CUSTOMER/ Sub-Developer. Sub developer shall design and connect the ETS at this tie-in point.

Any piling works for the basement construction adjacent to the infrastructure DC tie-in point shall be protected by the Sub-developer to ensure that the existing infrastructure DC pipe is not damaged.

7.2 Jointing

Works on the primary district cooling side (and also on the secondary cooling system if direct connection is used) should be carried out by the company with welding license and certified welders who carried out the approved welder qualification test in accordance with EN287-1 or passed brazing tests according to Qualification on Copper pipes as with BS 1724 or equal.

Installation of valves in primary district cooling system must use a welding method that will not cause damage to the valve seal. Therefore it requires electric fusion welding if the weld is located at shorter distances than 0.5 m away from the valve house. In addition the valve supplier's recommendations shall be followed.

7.3 Insulation

In order to avoid condensation of moisture from the air on the pipes, valves and other components, shall be insulated. In order to avoid condensation water from drip, the facility should be equipped with drip trays and isolated with vapor barrier.

Insulation shall be of closed cell elastomeric/ cellular rubber which is glued together, edge to edge. The recommended insulation thickness for chilled water pipe line is 50 mm thick cellular rubber with 1 mm thick aluminium cladding inside the ETS room.

Polyurethane foam with the top layer of Aluminum is used for high requirements on vapor barrier and resistance against mechanical impact.

Removable Insulation jackets for heat exchangers are recommended to be provided from the PHE manufacturer.

Generally insulation work shall be carried out by an approved specialist for thermal insulation contractor.

7.4 Tagging

Pipes, valves and equipment shall be tagged according BS 1710 or equal.

Each item of equipment shall be identified by using white non-corroding shatterproof laminated plastic labels engraved with black letters, 6mm high, the function and number of each piece of equipment, i.e. primary chilled water pump, pump numbers, etc. All labels shall be fixed with screwed, riveted or glued to equipment cover. Where a piece of equipment is insulated the identification label shall be fixed to the external surface of the insulation.

Valves shall be tagged with identification discs attached with a split ring, S-hook or brass chain, whichever is the most appropriate. All primary and secondary chilled water pipe work shall have self-coloured, self-adhesive PVC tape bands colour coded in accordance with BS 1710 so far as this is applicable and at suitable intervals.

7.5 CHANGES TO THE SYSTEM

Once the design has been approved, the CUSTOMER should not change or replace any equipment during the installation without informing MARAFEQ. Any future changes to the building's cooling water system that will impact the DC system must be reported to and, when appropriate, reviewed by MARAFEQ.

The CUSTOMER is responsible for maintaining his system so that it continues to perform as intended.

If warranted by changes in temperatures and flow conditions, the CUSTOMER should verify that his side of the ETS is properly balanced.

8 APPENDICES

- Appendix 1: Application for "Design Conformance Certificate"
- Appendix 2: ETS Examination summary for "ETS Conformance Certificate"
- Appendix 3.1: PI&D - Schematic of ETS installation for Single Heat Exchanger
- Appendix 3.2: PI&D - Schematic of ETS installation for Multiple Heat Exchanger
- Appendix 4.1: Compliance statement for Plate Heat Exchanger
- Appendix 4.2: Compliance statement for Pressure Independent Control Valve
- Appendix 4.3: Compliance Statement for primary side isolation Valve (Ball Valve)
- Appendix 5: Programmable Logic Control system (PLC System)
- Appendix 6: Bulk Meter Guidelines
- Appendix 7.1: Compliance statement: Method statement for Installation, Testing and Commissioning of Equipment inside ETS (Primary side)
- Appendix 7.2: Compliance statement: Method statement for Hydro static test (Primary side)
- Appendix 7.3: Compliance statement: Method statement for Flushing/Pipe conditioning (Primary side)

Notes:

Appendix 1 shall be submitted along with DC-1 approval

Appendix 2 shall be submitted during testing and commissioning of ETS

Appendix 3.1 and 3.2 shall be used as guideline to develop Customer specific ETS design

Appendix 4.1, 4.2 and 4.3 shall be submitted as part of Material Approval Submittal.

Appendix 5 and 6 shall be used for procurement and installation of Energy Metering and PLC System.

Appendix 7.1, 7.2 and 7.3 shall be submitted as a part of Method statement.



Application for “District Cooling Design Conformance Certificate”

DETAILS OF BUILDING				
District Name				
Plot No.				
Building Name				
COOLING DEMAND (1TR = 3.517 kW)				
Gross Floor Area (GFA)	m ²			
Net Floor Area (NFA) – Cooled Area	m ²			
AHU (Air handling Units)	TR		kW	
FCU (Fan Coil Units)	TR		kW	
ERU (Energy Recovery Units)	TR		kW	
Process cooling	TR		kW	
Others (Specify)	TR		kW	
Total Cooling Demand	TR		kW	
DISTRICT COOLING SYSTEM (PRIMARY)				
PHE Supplier / Type				
Qty. of PHE				
Total Design flow (m ³ /h)				
Design temperature °C (In/Out)				
Pressure loss over ETS at DC tie in point (kPa)				
BUILDING COOLING SYSTEM (SECONDARY)				
Total Design flow (m ³ /h)				
Design temperature °C (In/Out)				
Pressure loss (kPa)				
PRESSURE INDEPENDENT CONTROL VALVES (PICV) :PRIMARY SIDE				
Qty. of PICV & Supplier				
Flow (m ³ /h)				
Pressure loss (kPa)				

Compliance Statement:

The design shall comply with Marafiq Technical Guidelines for the connection of ETS Document No: LUS-CPALL-MAQ-SPE-UT-00004 without any exception unless otherwise a written confirmation from Marafiq Qatar is provided.

The design and installation liabilities/responsibilities remain with the Sub-developer/Owner at all times.

Date :

(Signature and Stamp of Sub-developer / Owner)



Appendix:2

ETS Examination Summary

ETS ID:

Date:	Executed by:
Customer/Company:	Type of control:

DISTRICT COOLING SYSTEM

BUILDING COOLING SYSTEM

Meter readings		Temperature District Cooling		Secondary side	
1 Energy	TRh	6 Temperature supply	°C	8 Temperature supply	°C
2 Volume	m ³	7 Temperature return	°C	9 Temperature return	°C

Pressure		Other	
3 Supply, before strainer	MPa/kPa	10 Outside temperature	°C
4 Supply, after strainer	MPa/kPa		
5 Return	MPa/kPa		

S. No	System / component	Fault Description / Remark (Status: 1=Acute, 2=Action needed, 3=Info, 4=Executed by)	Status 1-4	Proposed Action
	District Cooling System			
	Isolating valves			
	Strainer			
	Pressure sensors			
	Temperature sensors			
	Flow Meter			
	Energy Meter			
	Temperature transmitter			
	PDT			
	PHE			
	PLC			
	Control valve (PICV)			
	Buildings Cooling System			
	Strainer			
	Pressure sensors			
	Temperature sensors			
	Pumps			
	Expansion tank / safety valve			
	Flow Sensor Switch			
	Pump By-pass			
	VFD			
	Other Equipment			

APPENDIX 3.1

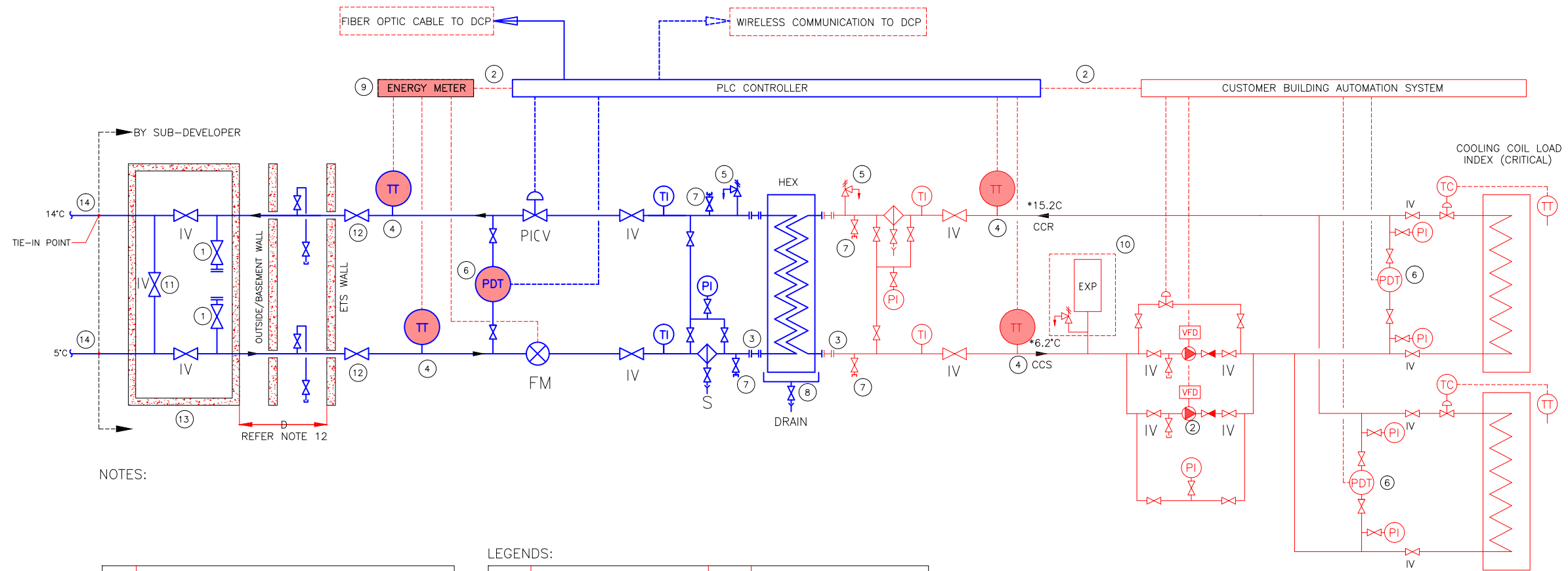

NOTES:

①	FLUSHING AND TEMPORARY CONNECTIONS. MAX ONE STEP LESS THAN MAIN PIPE.
②	MOD BUS INTERFACE TO CUSTOMER BUILDING AUTOMATION SYSTEM, FOR MONITORING ONLY.
③	FLANGED SPOOL PIECE MINIMUM LENGTH; TO FIT ONE FULL SIZE BEND
④	THERMOWELL AND TEMPERATURE TRANSMITTER
⑤	ROUTE SAFETY RELIEF VALVE DISCHARGE TO HEAT EXCHANGER DRAIN PAN.
⑥	PRESSURE DIFFERENTIAL TRANSMITTER ACROSS THE TWO MOST HYDRAULICALLY REMOTE LOADS.
⑦	DRAIN AND AIR VENT WITH HOSE CONNECTION (DN50) FOR CIP
⑧	DRIP TRAY WITH DRAIN
⑨	ENERGY METER FOR BILLING.
⑩	EXPANSION UNIT
⑪	BY-PASS CONNECTION. MAX ONE STEP LESS THAN MAINPIPE
⑫	PROVIDE ISOLATION VALVES IF D > 10m
⑬	VALVE CHAMBER WITH BYPASS AND TEMPORARY CONNECTION TO BE CONSTRUCTED WITHIN PLOT SETBACK. USE FACTORY PRE-INSULATED BALL VALVE & PIPE.
⑭	PLOT TIE-IN POINT (WELDED CONNECTION) (POINTS OF DELIVERY AND RETURN)

- PROVIDE VENTS AND DRAINS AT ALL HIGH/LOW POINTS AND/OR AS SHOWN IN LAYOUTS AND SECTIONS.
- ROUTE DRAINS TO NEAREST FLOOR DRAIN.
- PRIMARY SIDE ISOLATION VALVE (IV) SHALL BE WELDED BALL VALVE.
- INDICATIVE VALUES ONLY. CUSTOMER TO DESIGN THE CHILLED WATER TEMPERATURES ON SECONDARY SIDE BASED ON THE BUILDING SIDE A/C DESIGN WITH DELTA T OF 9°C.

LEGENDS:

SYM.	DESCRIPTION	SYM.	DESCRIPTION
— (Blue)	PRIMARY CHILLED WATER SYSTEM (DC)	⋈	VALVE
— (Red)	SECONDARY CHILLED WATER SYSTEM (CC)	⋈	2-WAY CONTROL VALVE
Ⓟ	PRESSURE TRANSMITTER	⋈	CHECK VALVE
Ⓟ	PRESSURE INDICATOR	⋈	WITH THREADED CAP
Ⓟ	TEMPERATURE TRANSMITTER	⋈	STRAINER WITH BLOW OFF VALVE
Ⓟ	TEMPERATURE INDICATOR	⊗	FLOW METER
Ⓟ	PRESSURE DIFF. TRANSMITTER	⊗	PUMP
Ⓟ	VARIABLE FREQUENCY DRIVE	Ⓟ	INSTR. TAG
DCS	DISTRICT COOLING SUPPLY	Ⓟ	WITH HOSE CONNECTION
DCR	DISTRICT COOLING RETURN	Ⓟ	PSV
CCS	CUSTOMER COOLING SUPPLY	Ⓟ	FLOW ARROW
CCR	CUSTOMER COOLING RETURN		
IV	ISOLATION VALVE		
---	MOD BUS COMMUNICATION		
■	SUPPLY BY MARAFEQ AND INSTALLATION BY CUSTOMER		

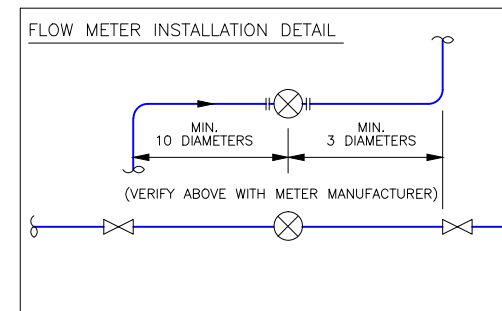

DRAWING TITLE:

ETS-GENERAL DISTRICT COOLING PIPING AND INSTRUMENTATION DIAGRAM FOR SINGLE HEAT EXCHANGERS

DRAWING NO. LUS-CPALL-MAQ-DWG-UT-10601

DATE:12.11.2014

APPENDIX 3.2

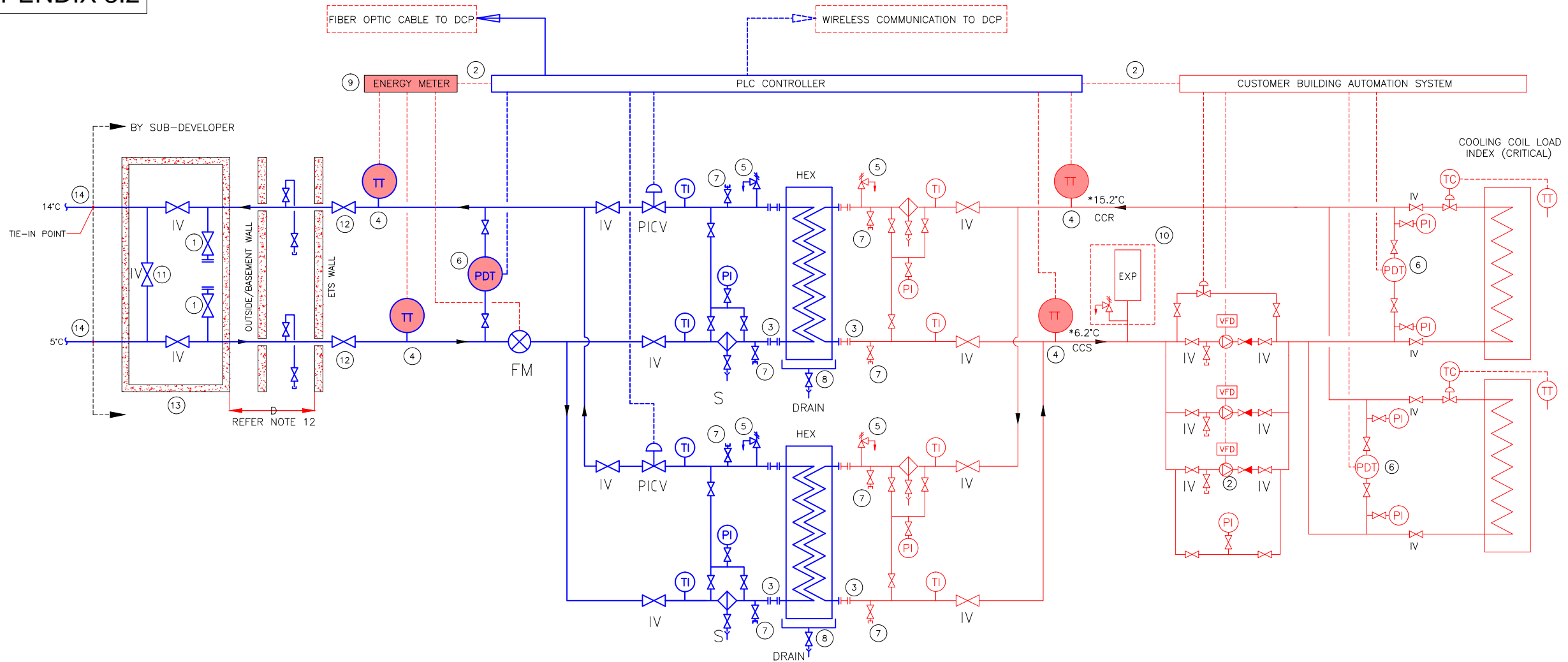

NOTES:

①	FLUSHING AND TEMPORARY CONNECTIONS. MAX ONE STEP LESS THAN MAIN PIPE.
②	MOD BUS INTERFACE TO CUSTOMER BUILDING AUTOMATION SYSTEM, FOR MONITORING ONLY.
③	FLANGED SPOOL PIECE MINIMUM LENGTH; TO FIT ONE FULL SIZE BEND
④	THERMOWELL AND TEMPERATURE TRANSMITTER
⑤	ROUTE SAFETY RELIEF VALVE DISCHARGE TO HEAT EXCHANGER DRAIN PAN.
⑥	PRESSURE DIFFERENTIAL TRANSMITTER ACROSS THE TWO MOST HYDRAULICALLY REMOTE LOADS.
⑦	DRAIN AND AIR VENT WITH HOSE CONNECTION (DN50) FOR CIP
⑧	DRIP TRAY WITH DRAIN
⑨	ENERGY METER FOR BILLING.
⑩	EXPANSION UNIT
⑪	BY-PASS CONNECTION. MAX ONE STEP LESS THAN MAINPIPE
⑫	PROVIDE ISOLATION VALVES IF D > 10m
⑬	VALVE CHAMBER WITH BYPASS AND TEMPORARY CONNECTION TO BE CONSTRUCTED WITHIN PLOT SETBACK. USE FACTORY PRE-INSULATED BALL VALVE & PIPE.
⑭	PLOT TIE-IN POINT (WELDED CONNECTION) (POINTS OF DELIVERY AND RETURN)

1. PROVIDE VENTS AND DRAINS AT ALL HIGH/LOW POINTS AND/OR AS SHOWN IN LAYOUTS AND SECTIONS.
2. ROUTE DRAINS TO NEAREST FLOOR DRAIN.
3. PRIMARY SIDE ISOLATION VALVE (IV) SHALL BE WELDED BALL VALVE.

* INDICATIVE VALUES ONLY. CUSTOMER TO DESIGN THE CHILLED WATER TEMPERATURES ON SECONDARY SIDE BASED ON THE BUILDING SIDE A/C DESIGN WITH DELTA T OF 9°C.

LEGENDS:

SYM.	DESCRIPTION	SYM.	DESCRIPTION
— (Blue)	PRIMARY CHILLED WATER SYSTEM (DC)	⊘	VALVE
— (Red)	SECONDARY CHILLED WATER SYSTEM (CC)	⊘	2-WAY CONTROL VALVE
PT	PRESSURE TRANSMITTER	⊘	CHECK VALVE
PI	PRESSURE INDICATOR	⊘	WITH THREADED CAP
TI	TEMPERATURE TRANSMITTER	⊘	STRAINER WITH BLOW OFF VALVE
TC	TEMPERATURE CONTROLLER	⊘	FLOW METER
TI	TEMPERATURE INDICATOR	⊘	PUMP
PDT	PRESSURE DIFF. TRANSMITTER	⊘	INSTR. TAG
VFD	VARIABLE FREQUENCY DRIVE	⊘	WITH HOSE CONNECTION
DCS	DISTRICT COOLING SUPPLY	⊘	PSV
DCR	DISTRICT COOLING RETURN	⊘	FLOW ARROW
CCS	CUSTOMER COOLING SUPPLY		
CCR	CUSTOMER COOLING RETURN		
IV	ISOLATION VALVE		
---	MOD BUS COMMUNICATION		
■	SUPPLY BY MARAFEQ AND INSTALLATION BY CUSTOMER		

4. BURIED PIPE SHALL BE PRE-INSULATED.

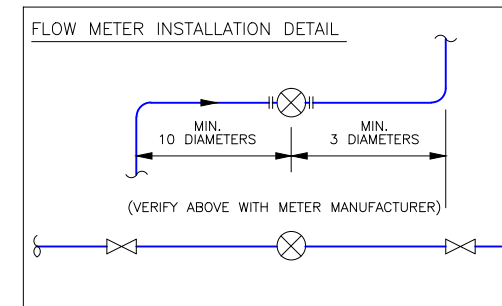

DRAWING TITLE:

ETS-GENERAL DISTRICT COOLING PIPING AND INSTRUMENTATION DIAGRAM FOR MULTIPLE HEAT EXCHANGERS

DRAWING NO. LUS-CPALL-MAQ-DWG-UT-10600

DATE:12.11.2014



Appendix:4.1

Marafeq Technical Requirements for the connection of ETS(s) to the District Cooling System

Compliance Statement: Plate Heat Exchangers Specifications

S. No	Description	Status
A	Technical Requirements	
1	Type: Counter-current flow.	
2	The material of the heat exchangers (PHE) must withstand both systems liquid media.	
3	PHE shall be designed, built and marked in full compliance to AHRI-400 Liquid-to-Liquid Plate Heat Exchangers with Zero tolerances.	
4	Manufacturers of heat exchangers should be able to show that heat exchangers meet the test program described in the standard EN 1148 or equal. The control also include the manufacturer's data programs are consistent with product performance. Use the latest version of the design program.	
5	In order to make CIP (Cleaning in Place) of PHE plates possible, the ETS shall have connections installed. CIP is done without dismantling the PHE. In order to save CIP chemicals, the water volume shall be reduced to a minimum. For this isolating valves should be located closely to the PHE.	
6	Maximum HEX pressure drop at design flow is 60 kPa(Select the HEX to ensure that overall primary side pressure drop shall not exceed specified value in the ETS guideline)	
7	If unit is sized for future expansion allowance, this shall be based on flow capacity, by installing additional plates in future, with the following limitations: a) Design temperatures shall remain the same. b) Pressure drops across the heat exchanger shall not increase by more than 10% above design conditions (Do not exceed the primary side overall pressure drop from specified value in the ETS guideline). c) Additional capacity is obtained without changing frame size.	
8	The design shall prevent fluid intermixing and provide leakage to outside of unit.	
9	The unit shall withstand the maximum 16 bar gauge design pressure on primary side with opposite side at 0 psig gauge. Similarly unit shall withstand the maximum design pressure on secondary side with opposite side at 0 psig gauge.	
10	Provide visible metal nameplate with location identification in accordance with schedule. - Include design flow in l/sec - Include design kW (TR) - Hot side and cold side temperature in and out, Deg.C. - Hot side and cold side pressure drop, kPa - Design temperature differential, Deg.C. - Provide metal tags to label inlet and outlet connections for hot side and cold side of heat exchanger.	
11	A safety relief valve shall be located between the isolation valves at each heat exchanger in order to prevent over pressure during shut downs. The customer shall submit calculations and sizing information to Marafeq for approval.	
B	Service Conditions (Particular Conditions)	
1	Design Pressure : 16 Bars (minimum) Note -1	
2	Test Pressure: 23 Bars (1.5 times design pressure)	
3	Suitable for water Temperature Condition : Supply: 4-10 °C, Return: 6-20 °C	
4	Suitable for ambient temperature : 50 °C	

Note 1: PHE pressure rating should be greater than static head (building height) and pump shut-off head.

Signature and Stamp of Consultant

Date:

Signature and Stamp of Contractor/Supplier

Date:

Appendix:4.2

Marafeq Technical Requirements for the connection of ETS(s) to the District Cooling System Compliance Statement for Pressure Independent Control Valve (PICV)

S. No	Description	Status
A	Technical Requirements	
1	Provide one no Pressure Independent Control valve for each PHE.	
2	The Control valve is suitable for precise control and shall maintain linear characteristic under all operating condition.	
3	Valve rating is suitable for Network Design Pressure: 16 bar, Test pressure: 23 bar, Differential Pressure -10 bar.	
4	Mention pressure drop across PICV for full flow condition.	
5	Confirm that Valve Pressure drop (for full flow) is accounted in determining the maximum allowed pressure drop of 150 kPa at nominal flow and subscribed load between incoming isolation valve at the wall penetration.	
6	Pressure Independent control valves (PICV) shall be installed as shown in the drawings and strictly as per the recommendations of the manufacturer.	
7	These valves shall be of pressure independent design and shall consist of two functional items. First part is a two way modulating control valve with electric actuator and the second part is an integral and external differential pressure control valve.	
8	The differential pressure control valve shall sense and regulate the differential pressure across the modulating control valve, as per the control valve selection at all flow and pressure conditions.	
9	The valves shall be manufactured in accordance with ISO 9001 quality standards.	
10	The complete assembly of PICV shall be manufacturer's factory assembled and be ready for field installation.	
11	Each valve set shall be pre-calibrated at manufacturer's works to a specified flow and differential pressure, which shall be field adjustable without the removal of the actuator.	
12	Control valve rangeability shall be 100:1. The actuators provided with the valve(s) shall assure 100:1 turndown.	
13	Each control valve shall be individually flow tested and factory verified to deviate not more than $\pm 5\%$ through the selected operating pressure range.	
14	A calibrated performance tag shall be provided with each valve that verifies the flow rate in 10° rotation increments up to full rated flow. All testing shall be performed with instruments calibrated to the requirements of ANSI/NCSS Z540-1-1994 with traceability to NIST and/or ISO standards. The flow verification shall be performed at the manufacturer's works	
15	Class IV leakage or better is required for control valves up to 50 mm diameter and Class III or better for valves larger than 50 mm, as per ANSI leakage testing standards.	
16	All valves shall have three integral test ports, factory installed, capable of being used to measure pressure or temperature.	
17	The control valve flow adjustment stem shall extend out from the control valve and have an indicator that shall be used to verify valve position. The control valve shall have tapped mounting holes for mounting the control valve actuator bracket. The actuator shall rotate the valve stem to	

Appendix:4.2

S. No	Description	Status
	provide the required flow independent of pressure across the valve.	
18	Control valves shall be compatible with modulating actuators from all major manufacturers. Actuators shall modulate all valves from 0 to 100% design flow while rotating the valve stem a maximum of 90°. Valve percentage opening and closing indication is required.	
19	Valve actuators shall be factory mounted.	
20	Actuators shall be selected based on system close-off requirements. Valves and actuator shall be capable of a close-off rating of 16 bar.	
21	Torque requirements for actuator selection shall be provided by the valve manufacturer	
22	For electric actuation it shall be possible to set the end stroke of the actuator with mechanical stops, signal adjustment or a control signal limit at the full design flow listed on the performance tag furnished with each valve.	
23	Valve actuators shall be suitable for fail safe position. In case of power failure valve shall retain its last position.	
24	Electric actuator shall be suitable for input and output 4-20 mA control signal.	
25	Manufacturer of pressure independent control valves shall confirm balancing valves and associated balancing shall not be required where pressure independent modulating control valves are installed.	
26	Pressure Independent control valves shall be suitable for thermal insulation all around.	
27	Compliance to this specification shall be submitted along with the material submittal for Employer/ Engineer's approval.	
28	Control valves together with actuators shall be suitable to work at ambient temperature of 0 to 50 °C and relative humidity of up to 100%.	
29	Actuator housing shall be IP 54 rated or higher.	
30	Valve actuator shall have remote, local and stop selector switch /push button its visual indication on the valve.	
31	Control valve shall have control option for Remote (HMI , SCADA) and local operation.	
32	Control valve shall have Remote, Local And Stop hardware digital input (Potential free contact) to ETS PLC.	
33	Control valve shall have manual hand wheel option.	

Signature and Stamp of Consultant

Date:

Signature and Stamp of Contractor/Supplier

Date:

Appendix:4.3

Marafiq Technical Requirements for the connection of ETS(s) to the District Cooling System Compliance Statement: Ball Valves (Primary side)

S. No	Description	Status
1	All isolation valves on primary side shall be welded type. All Valves shall be of industrial standard. Flanges are not allowed.	
2	Primary system valves must be pre-insulated or thermally insulated with closed cell elastomeric material type with a protective jacket.	
3	Main isolation valves for bypass and emergency supply shall be located in the valve chamber/directly inside the building as close as possible to the walls. Connection to the district cooling network shall be by welding.	
4	Isolation valves must be provided in the supply and return pipe around the heat exchanger(s) to allow for maintenance and cleaning.	
5	For welded valves, caution is needed so that the seals in the valves will not be damaged during the welding process.	
6	All valves shall be easily accessible and tagged according to with BS 1710 or equal.	
7	Valve shall be capable to perform at design pressure of 16 bars and test pressure of 23 bars.	
8	Provide hand wheel and gear box for valves DN 200 and above.	
9	Provide chain operators for elevated valves. Chain operation shall be provided for valve DN 65 and larger, located 2.2 m (7 feet) or higher above finished floor level. Chain shall be extended to elevation of 1.5 m (5 feet) above finished floor level.	
10	Ball seats shall be spring-loaded.	
11	Stem shall be provided with double sealing, minimum two O-rings and the upper one shall be changeable from the top without draining the pipeline. (The O-rings are FPM (fluorine rubber/fluoro packing material/VITON) rubber material.	
12	Valve shall be full port valve. Reduced port valves are acceptable only if maximum allowable pressure loss of 150 kPa at nominal flow and subscribed load between isolation valves at ETS entrance can be maintained with reduced port valves.	
13	Valve shall be provided with position indicator that shows the ball's position in the valve.	
14	Valves shall be delivered with plastic end caps (flow port protectors) in order to avoid debris in the valves, during transportation, storing and handling.	

Signature and Stamp of Consultant

Date:

Signature and Stamp of Contractor/Supplier

Date:

SECTION A: PROCESS CONTROL PANELS AND HARDWARE

PART 1 GENERAL

1.01 SECTION INCLUDES

- A. ETS controller cabinets /enclosures completely assembled with instruments and electrical controls mounted and wired to terminal strips for field connections.
- B. The bulk-meter described in the **Appendix 6** shall be installed on the front door of PLC panel or inside the IP rated lockable cabinet enclosure with window glass as per the site conditions and integrated with the PLC system.
- C. Mount and wire process controller, I/O chassis, power supplies, industrial Ethernet switch, and UPS in cabinets/enclosures.

1.02 INFORMATIONAL SUBMITTALS

- A. Cabinet-mounted instruments: Tabulation of equipment including accessories listed separately where not assembled with equipment item. Tabulation shall include item number, service equipment description, or identification, part or catalog number and other information helpful to installation of equipment and coordination of Project.

1.03 ACTION SUBMITTALS

- A. Pre-purchase: Submit information relating to instrumentation and control devices referencing instrument tag number listed on submittal documents.
- B. Pre-construction:
 - 1. ETS controller cabinet cabinet/enclosure:
 - a. Cabinet exterior general arrangement drawings showing location of surface and flushed mounted equipment.
 - b. Cabinet interior arrangement drawings including:
 - 1) Locations and identification of terminal blocks.
 - 2) Locations and identification of racks/chassis and equipment mounted within.
 - 3) Arrangement of other equipment mounted inside cabinet identified by instrument tag number.
 - 4) Exterior cabinet wiring interface termination diagrams.
 - 5) List of nameplate legends and sizes for cabinet-mounted equipment.
 - c. Schematics and wiring diagrams identifying terminals, circuits, color of wire, and cable/wire numbers. Cable and wire numbers for external wiring will be assigned by electrical contractor. Cable, wire, and terminal numbers for cabinets shall be assigned by cabinet provider. Cable, wire, and terminal numbers shall be instrument tag number oriented. Coordinate with electrical contractor to avoid duplication of wire and terminal numbers.

Appendix:5 Programmable Logic Controller (PLC)

2. Cabinet-mounted instruments:

Manufacturer's data and/or specification sheets for control and instrument items, showing design parameters, equipment catalog designations, calibration range, features and options provided. All sheets shall be identified with corresponding instrument tag numbers.

1.04 CLOSEOUT SUBMITTALS

A. Operation and maintenance manual:

1. Complete instruction manuals and parts lists covering installation, operation, and maintenance of cabinet-mounted devices. Manuals shall include interface drawings defining terminal numbers and functions for interface with other instruments and equipment.
2. Schematic and wiring diagrams for each cabinet/enclosure. Show color of wire, termination points, terminal numbers, cable, and wire numbers.
3. List of spare Parts to be provided

B. Project record documents: "As-built" schematics and wiring diagrams defining terminals, cables, and wire numbers as defined above.

1.05 MAINTENANCE MATERIALS

A. Cabinet manufacturer shall supply separately packaged spare parts of following items:

1. Fuses: 100% of each rating furnished with control equipment and used internally within the cabinet/enclosure for circuit protection including, but not limited to, miscellaneous fuses on controllers, recorders, and indicators. Minimum of one standard package for each type and rating used.
2. Indicating lamps: 10% of each type furnished with control equipment. Minimum of one standard package for each type and rating used.
3. Relays: 10% of each type furnished with cabinet/enclosure. Minimum of one for each type and rating used.

1.06 DELIVERY, STORAGE AND HANDLING

- A. Ship control cabinets as recommended by control cabinet/enclosure manufacturer.
- B. Provide removable eye-bolt lifting lugs for large cabinets and suitable skids for safe handling.
- C. Remove rack-mounted instruments, controllers, recorders, and indicators that could be damaged by shipment and package in original shipping cartons.

Appendix:5 Programmable Logic Controller (PLC)

1.07 SITE CONDITIONS

A. Indoor applications:

1. Temperature: 4 to 50°C (40 to 122°F).
2. Humidity: 10 to 90%.

B. Outdoor applications:

1. Temperature: -1 to 55°C (30 to 130°F).
2. Humidity: 10 to 100%.

Electrical power source: 240-volts ac, 50 Hz.

PART 2 PRODUCTS

2.01 FABRICATION

A. Size:

Sufficient to house PLC, HMI, chassis, input/output cards, power supplies, terminal strips uninterruptible power supply, communication devices, and necessary hardware and instruments required for each application. Provide 25% additional space for future expansion. Panel mounted display units shall be provided for man machine interface PLC shall be of modular construction with plug in I/O cards and facility to install expansion modules when necessary. The PLC shall have a real time clock with battery backup. PLC used for controlling functions shall have a minimum redundancy of Power Supply.

B. PLC diagnostic indications shall include the following:

1. Power OK
2. Low battery
3. Forced I/O
4. CPU fault
5. I/O status indicators

C. Central Processing Unit

The CPU shall perform the following functions:

1. Scan all inputs, execute relay ladder logic programs and generate outputs for the final control elements.
2. Monitor status of the system hardware and provide diagnostic information.
3. The process scan time shall be 6ms/k minimum.

D. Random access memory (RAM) for real time progress execution with lithium battery backup for data retention and EEPROM flash backup for permanent storage shall be provided. The PLC memory shall be as required for the programs and future requirements with a minimum of 1 MB flash / 750 K SRAM, with a minimum of 204 K for IEC Logic or equivalent.



Appendix:5 Programmable Logic Controller (PLC)

E. Input/output module: Analogue input modules shall be for current, voltage, RTD Pt 500 or Thermocouple input type with a 16 bit resolution. Power supply for 2 wire transmitters shall be provided where specified. Analogue outputs shall be isolated 4-20 mA d.c with 14 bit resolution, unless otherwise specified. Digital I/Os shall be optically isolated. The systems shall support on-line replacement of I/O modules, in case of failure.

F. PLC programming shall be comply IEC 61131-3 standard on programming languages for PLC.

G. Interface. PLC shall be provided with serial and Ethernet IP interface ports for communication.

H. Oil-resistant gasket attached with oil-resistant adhesive.

I. Provide each panel/enclosure with industrial corrosion inhibitor emitters of sufficient size and quantity to protect contents of enclosure size selected. Emitters shall contain additional red metal inhibitors to protect brass and copper material in addition to ferrous metals.

J. Provide "data pockets" on inside face of panel to store drawings and other documents. Provide folding type laptop stand fixed with the panel door

K. Subcabinets: Provide for full surface mounting of terminal blocks, wireways, power supplies, racks, chassis, and instruments.

L. Free-standing panels:

1. Panels shall mount on 76.2 mm (3-inch) concrete pad.
2. Enclosures of front of panel mounted instruments shall be of uniform design and color scheme wherever possible. Front of enclosure colors shall be compatible with panel colors and subject to final approval by the sub-developer. Normally, compatible standard colors of the manufacturer shall be acceptable
3. Control panel shall be self-supporting with angle iron or plate framework as necessary to obtain proper stiffness and support.
4. Fabricate control panel of 12-gage carbon steel plate with all-welded construction throughout. Welds shall be ground smooth, corners shall be rounded, and weld spatter cleaned. Corner construction shall be minimum of 31.75 mm (1/8 inch) e radius. Control panel construction shall meet IP55 standards, unless otherwise indicated.
5. Surface of control panel shall be free from mars and defects. Finished panel surfaces shall be flat within 1.5 mm in 2 meters and be smooth with rounded edges. Finished panel surfaces shall be 4.5 mm thick. Instrument cutouts and drilling shall be straight and true.
6. Provide 10-gage full height front access doors. Access doors shall have triple-point latch, stainless steel handle and lock, full length stainless steel "piano" type hinge, and sponge rubber gaskets. Door shall be supplied with limit switch for activation of internal maintenance light and devices to hold door in 105° position when fully opened.

Appendix:5 Programmable Logic Controller (PLC)

7. Provide full-width subcabinet for surface mounting of programmable controller, other surface-mounted instruments, wiring troughs, and terminals strips.
8. Base of control panel shall be adequately reinforced to permit anchoring to concrete pad.
9. Mount and segregate chassis, input/output cards, power supplies, communication devices, and miscellaneous hardware in control cabinet sections to allow for minimal wiring between each control cabinet section.
10. Control cabinet shall have top cable entry.
11. Supply 4 identical master keys which will operate all locks of each control panel.

2.02 CABINET-MOUNTED INSTRUMENTATION

A. Control relays:

1. Function: General logic hardware interlocks.
 - a. Type: Plug-in.
 - b. Construction: Continuous duty.
 - c. Coil voltage: 240-volt ac, 50 Hz or 24-volt dc as required.
 - d. Switch configuration: 3-SPDT.
 - e. Indication: Neon light to indicate energized relay.
 - f. Switch rating: 10 amperes at coil voltage.
 - g. Mounting: Socket for DIN-rail mounting.
 - h. Accessories: Indicator lamp and manual operator, as available in model specified.
2. Function: Interposing relay for PLC output.
 - a. Type: Plug-in.
 - b. Construction: Continuous duty.
 - c. Coil voltage: 24-volt dc as required.
 - d. Switch configuration: 2-SPDT.
 - e. Indication: Neon light to indicate energized relay.
 - f. Switch rating: 10 amperes at coil voltage.
 - g. Mounting: Socket for DIN-rail mounting.
 - h. Accessories: Indicator lamp and manual operator, as available in model specified.

B. Selector switches:

1. Type: Non-illuminated.
2. Configuration: Number of poles as required for application.
3. Contact rating: 10 amperes at 240-volts ac, 50 Hz.
4. Operator function: As required for application.

Appendix:5 Programmable Logic Controller (PLC)

5. Legend plates: As required for application, subject to Marafeq Qatar review.

C. Pushbuttons:

1. Type: Non-illuminated.
2. Configuration: Number of poles as required for application.
3. Contact rating: 10 amperes at 240-volts ac, 50 Hz.
4. Operator:
 - a. Flush head: Start or Reset applications.
 - b. Extended head: Stop applications.
 - c. Mushroom head: Emergency stop applications.
5. Button color:
 - a. Red: Stop or close applications.
 - b. Green: Start or open applications.
 - c. Black: Reset or non-descriptive applications.
6. Legend plates: As required for application subject to Marafeq Qatar review.

D. Time delay relays:

1. Function: Interaction with relay logic for flow switch time delay and pump failure time delay.
2. Construction: CMOS integrated circuit.
3. Coil voltage: 240-volt ac, 50 Hz, or 24-volt dc, as required per application.
4. Switch configuration: SPDT, minimum.
5. Switch rating: 3 amperes at coil voltage, minimum.
6. Mounting: DIN rail mounting with socket, if applicable.
7. Adjustment: Field selectable modes, ranging from 0.1 second to 60 hours, minimum:
 - a. ON-delay.
 - b. Repeat cycle.
 - c. Signal Interval/OFF delay.
 - d. Signal ON/OFF delay.
 - e. Interval.
 - f. Cycle one-shot.

E. Low-voltage interposing relays:

1. Function: Interface open collector transistor outputs from UPS.

**Appendix:5
Programmable Logic Controller (PLC)**

2. Type: MRS 24 V-volt dc SPDT.
3. Electrical connection: Screw.
4. Input voltage: 24-volt dc, $\pm 20\%$.
5. Output: SPDT relay contact, 6 Amp maximum load.
6. Mounting: DIN Rail.

F. Uninterruptible Power Supply (UPS):

1. Provide one UPS within each panel shall serve the programmable logic controller, human machine interface, energy meter, flow meter and panel light.
2. Total harmonic distortion: Less than 2.5%.
3. Backup time: 120 minutes.
4. Compliance: IEEE 519.

G. Provide 1 or more 24-volt dc power supply, as necessary, within each cabinet to power field transmitters, control devices, and control system I/O. Amperage shall be 200% of required capacity. Cabinet supplier shall fabricate 3-prong power cord to connect dc power supply to 240-volt source.

H. Fiber/Copper Media Convertor (FO/Cu Media Convertor):

1. Provide Industrial FO/Cu Media Convertor to connect Ethernet-based devices within control enclosures.
2. Data rate: 10/100 MB.
3. Connection: RJ45 for Ethernet and Single Mode SM (SC).
4. Ports: 4 Ethernet and 2 FO, 1 Uplink.
5. Link Budget : 26.0 dB
6. Supply voltage: 240 volt ac 50 Hz or 24-volt dc.

I. Ethernet switch:

1. Provide Industrial Ethernet switch to connect Ethernet-based devices within control enclosures.
2. Data rate: 10/100 MB.
3. Connection: RJ45.
4. Ports: 8 Ethernet, 1 Uplink.
5. Supply voltage: 240 volt ac 50 Hz or 24-volt dc.
6. Switch type: Unmanaged, store and forward.

Appendix:5 Programmable Logic Controller (PLC)

J. Signal splitter:

1. Input signal: 4-20 mA, externally powered.
2. Output signals: Dual, independent, 4-20 mA, internally powered.
3. Power requirements: 24-volt dc.
4. Mounting: DIN rail.

K. Digital display:

1. Display: 4 digit (-1999 to 9999), 0.56-inch high.
2. Decimal point: Up to 3 decimal places.
3. Update rate: 3.7 to 5 times per second.
4. Input signal: 4-20mA, externally powered.
5. Output signal: Not required.
6. Relay outputs: None required.
7. Enclosure: 1/8 DIN, high impact plastic.
8. Electrical classification: IP 65 front.
9. Supply voltage: 24-volt dc.
10. Electrical connection: Screw terminal blocks.
11. Mounting: PLC enclosure.

2.03 FACTORY WIRING

- A. Provide complete factory wiring of control cabinet and equipment mounted thereon.
- B. Group and segregate process control system and communication devices, input/output cards, chassis, terminal boards, and associated hardware to allow for minimal wiring across shipping splits between individual control cabinet sections.
- C. Install continuous wire from terminal to terminal, splices will not be acceptable.
- D. Wire and cable:
 1. Analog signal cable:
 - a. Configuration: Twisted pair, shielded, and jacketed.
 - b. Insulation: 300-volt, 15-mil, 90°C, PVC, color-coded to permit identification of each conductor.

Appendix:5 Programmable Logic Controller (PLC)

- c. Conductors: 1.0 square mm, 7 strand copper, Class B.
 - d. Shield: Tinned copper braid providing 100% coverage against noise together with 0.5 square mm stranded tinned drain wire.
2. Power wire:
 - a. Rating: 600-volt, 90°C, PVC insulation/jacket.
 - b. Conductors: 2.5 square mm stranded copper.
3. Discrete signal wire:
 - a. Rating: 600-volt, 90°C, PVC insulation/jacket.
 - b. Conductors: 1.5 square mm, stranded copper.
- E. Group and route wire/cables from terminal blocks to cabinet-mounted instruments in separate wireways as follows:
 1. Low-voltage/low current dc analog signals, 30-volts/50 mA or lower.
 2. High-voltage dc alarm signals, 48-volts or greater.
 3. Low-voltage ac control signals, 240-volts or lower.
 4. High-voltage ac power signals, greater than 240-volts.
 5. Communication cable wiring.
- F. Wiring interfaces:
 1. External connections:
 - a. Install dedicated terminal strips for analog, discrete, and power signals.
 - b. Provide manufacturer's standard connectors for communications, digital data, and multiplexed signals.
 2. Provide separate terminal strips and wireways for 240-volt ac and 24-volt dc circuits.
 3. Terminal block requirements:
 - a. Type: High-density.
 - b. Voltage: 600-volt.
 - c. Wire range: To 2.5 square mm.
 - d. Termination: Screw clamp compression with pressure plate.
 - e. Mounting: Rail-mounted with end anchors and barriers.
 - f. Spare: Provide greater amount of 20% or 6 terminals per terminal strip
 4. Terminate maximum of 2 wires on single connect point.
 5. Wire network communication cables point-to-point rather than terminating on interposing terminal blocks.
 6. Install power distribution blocks to parallel feed to power control devices. Parallel wiring from instrument to instrument not acceptable.

Appendix:5 Programmable Logic Controller (PLC)

7. Provide 13 ampere, 10000 AIC circuit breakers on all power circuits with 2.5 square mm wire.
8. Provide plug-in strip for ac supply power to devices requiring ac power via power cord. Power strip shall be industrial quality, 3-wire, steel construction with power surge protection, circuit breaker, power switch, and pilot light. Minimum 1.5 square mm cable.
9. Circuit protection:
 - a. Install individual circuit breakers for protection of control cabinet power supply circuits as identified above.
 - b. Group circuit breakers on separate terminal strip away from low-voltage instrumentation circuitry.
 - c. Provide circuit breakers for protection of individual instrumentation circuits. Instrumentation circuits for field-mounted instruments may be combined in logical groupings of no more than 10 devices/signals.
10. Provide 2.5 square mm internal copper grounding bus for ground connections.

G. Wire tags:

1. Type: Embossed, heat-shrink tubing. Fiber tape tagging not acceptable.
2. Color: White.
3. Identify both ends of wires and/or cables with permanent wire marker.

H. Service equipment:

1. Fluorescent lighting fixtures of sufficient size and quantity to provide 300 to 500 meter-candles (lux) of illumination within freestanding cabinets. Wire to UL-approved switch mounted inside cabinet.
2. Duplex, 240-volt ac, 3-wire grounded type Ground Fault Circuit Interrupter convenience outlets.
 - a. Provide 1 duplex receptacle/1 sq. meter of subcabinet area, minimum 1.
 - b. Power service outlets from separate voltage source than instrumentation and PLC equipment, as defined above.

2.04 NAME PLATES

- A. Provide permanent nameplates for devices mounted on or within cabinets. Provide separate nameplates. Standard nameplates included with instruments not acceptable. Plastic tape labeling not acceptable.
- B. Type: Instrument nameplates shall be fabricated of laminated plastic, not less than 1.5 mm thick white Bakelite engraving stock with black core.
- C. Size: Outside cabinet surface shall be 25 mm x 50 mm, minimum.
- D. Lettering: Engraved, approximately 4.5 mm high, minimum, subject to Marafeq Qatar review.

**Appendix:5
Programmable Logic Controller (PLC)**

E. Attach nameplates with self-tapping screws.

2.05 PAINTS AND FINISHES

- A. Surfaces shall be commercial blast cleaned in accordance with ISO 8501-1:1988 (SSPC SP6).
- B. After preparation of surfaces, pits or indentations shall be filled with a 100% solid catalyzed epoxy putty compound.
- C. After hardening of putty filler, filled areas shall be sanded smooth. Entire exterior surface shall be smooth and uniform to receive paint.
- D. Manufacturer's standard interior and exterior paint shall be acceptable as primer coat.
- E. Prepare interior and exterior surfaces for finish coat of paint in accordance with manufacturer's instructions.
- F. Color:
 - 1. Interior and subcabinets: White.
 - 2. Exterior: Slate gray.
- G. Spray-apply paint to produce smooth, uniform coat, free of defects. SSPC PA-1 shall apply.
- H. Each coat shall be properly cured according to manufacturer's instructions before application of succeeding coats.

PART 3 EXECUTION

3.01 INSTALLATION

- A. Mount control panel in safe location that is clear of water pipes and minimizes potential for water spray or dripping onto the panel.
- B. Mount rigidly supported, level and plumb, and in such manner as to provide accessibility; protection from damage; isolation from heat, shock, and vibration; and freedom from interference with other equipment, piping, and electrical work.
- C. Do not install equipment until adjacent heavy construction work has been completed to extent that damage will be unlikely to installation by such construction work.
- D. Install in accordance with manufacturer's recommendations.

3.02 FIELD PERFORMANCE TESTING

- A. Coordinate between concerned parties and establish schedule for testing and inspection.
- B. Notify chilled water Provider, in writing, 10-day prior to start of field testing.
- C. Field performance tests:
 - 1. Conduct "On-Line," 24-hour per day, reliability test for 30 consecutive days of all hardware. Field instruments and interlocks shall be fully operational.



Appendix:5 Programmable Logic Controller (PLC)

2. Excessive downtime, as defined below, will result in 30-day guarantee period starting anew upon return to uptime.
 3. Downtime that is created by circumstances other than fault of process control equipment hardware will not cause guarantee period to start anew. Upon return to uptime, count of consecutive days will continue less days, or parts of days, of such downtime created by other circumstances.
 4. Equipment reliability:
 - a. First occurrence of any hardware component failure that is successfully repaired within 2 hours from start of occurrence shall not be included in determination of reliability performance.
 - b. Subsequent similar failures or failures not meeting preceding criteria will be included in determination of reliability performance.
 - c. Third similar occurrence of any hardware component failure meeting preceding criteria will result in guarantee period starting anew.
 - d. Reliability will be computed by dividing uptime by the sum of uptime and downtime. Maintain appropriate daily records of operation during field performance test period to compute reliability. Uptime and downtime will be measured in hours and whole minutes.
 - e. Hardware shall meet reliability test requirements within 60 days after initial date when reliability tests are started.
- D.** Submit certification that control panels passed testing and inspection and will satisfy requirements specified.

SECTION B: PROGRAMMABLE LOGIC PROCESS CONTROLLERS

PART 1 GENERAL

1.01 SECTION INCLUDES

- A. Programmable Logic Process Controller (PLC) software, PLC hardware, and PLC Human Machine Interface (HMI) displays.
- B. Installation and configuration of PLC software and graphics.

1.02 SITE CONDITIONS

- A. Indoor applications:
 - 1. Temperature: 4 to 50°C (40 to 122°F).
 - 2. Humidity: 10 to 90%.
- B. Outdoor applications:
 - 1. Temperature: -1 to 55°C (30 to 130°F).
 - 2. Humidity: 10 to 100%.
- C. Electrical power source: 240-volts ac, 50 Hz.

1.03 SUBMITTALS

- A. Submit design drawings to include programmable logic controller (PLC), I/O rack, CPU, memory module, power supplies, input/output (I/O) modules, interconnection wiring diagrams, schematics, and the manufacturer's detailed specifications.
- B. System network drawing indicating model numbers of items provided.
- C. Quality assurance data:
 - 1. Recommended spare parts list.
 - 2. Name and address of local supplier for spare parts.
 - 3. Name and address of nearest technical support. Provide description of technical support and availability for following:
 - a. Equipment, system software, and data communication.

Appendix:5 Programmable Logic Controller (PLC)

- b. Application software.
- D. Submit two (2) complete copies of the PLC program report documentation on paper for each system a minimum of two (2) weeks prior to system start-up as follows:
 1. Program listing report showing instruction addresses and symbols, address/instruction comments, rung comments, and cross reference data for the addresses in each rung.
 2. Cross reference report showing instruction mnemonics, address/instruction comment, file number and rung number.
 3. Processor configuration report showing type of rack, slot number, type of I/O module.
 4. Data table report showing input and output image, status, bit, timers, and counters.
 5. Source code communication protocol report.
- E. Submit power supply loading calculation for each rack.
- F. Submit operation and maintenance manuals to include the following:
 1. Vendor Installation Instruction manuals for all PLC components including, but not limited to, CPU module, power supply, I/O modules, and communication modules.
 2. Vendor User Manuals for all types of I/O modules supplied.
 3. Print out copy of final installed configured program for each PLC.

1.04 DELIVERY, STORAGE AND HANDLING

- A. Delivery, storage, and protection shall be in accordance with manufacturer's recommended procedures.
- B. Accept products on site in factory containers and verify damage.
- C. Store products in clean, dry area. Maintain temperature in accordance with NEMA ICS 1.

1.05 WARRANTY

- A. Vendor's warranty shall not begin until final acceptance of system by Marafeq Qatar, here final acceptance means complete ETS PLC system installation, commissioning, testing as per ETS PLC guideline and assistance to be provided to the DCP contractor by PLC system integrator(Sub-developer) for the seamless integration of ETS PLC to DCP PLC system.

1.06 MAINTENANCE

- A. Furnish 1 uninstalled spare for every 5 (or portion thereof) processors, power supplies, boards, modules, assemblies, and cables for PLC system.

PART 2 PRODUCTS

2.01 MANUFACTURER

- A. ABB, Allen Bradley, General Electric, Schneider Electric, Siemens.

2.02 PROGRAMMABLE CONTROLLER SYSTEM

Appendix:5 Programmable Logic Controller (PLC)

A. System shall provide following capabilities:

1. Control of chilled water flow through energy transfer station.
2. Modbus/M-Bus communication with BTU calculator for chilled water flow and temperature
3. Modbus communication with building automation system (BAS) to monitor the pump speed, pump status, start/stop, Bypass valve status. PDT, PDS.
4. Field instrumentation wiring terminations, instrument signal input/output for system, monitor and control functions, and self-diagnostics.
5. Data communication between processor and HMI on Ethernet IP over copper media.
6. Open network TCP/IP communication with district cooling plant over copper media.
7. UPS status (Main, Bypass, Trip, Battery low etc.) to be integrated with ETS PLC/HMI.
8. System hardware shall have sufficient data protection to prevent erroneous data communication during power-up or power-down.
9. System shall recognize transmission format errors and either correct or request retransmission.

B. Supply cabinets, consoles, power supplies, digital instrumentation, communications, interconnecting cables as required, and necessary voltage regulation or conditioning equipment for complete and operable system meeting performance and control description specifications.

C. Power supply: Main PLC processor: 240 volts ac, single-phase, 50 Hz.

D. Manufacturer shall have application training and customer assistance services available.

E. Major assemblies, subassemblies, circuit card, and devices shall be permanently marked with manufacturer's part or identification number.

F. Controller system shall be of modular design with plug-in processing unit, input/output frames or assemblies, and plug-in peripherals. Components shall be serviced and supported by same company.

G. Label I/O card strips with English descriptions.

2.03 PROCESSOR

A. Provide processor with following requirements:

1. I/O module support: Up to 8 modules on either side of processor.
2. Modular style to support power supply, CPU, and I/O modules.
3. CPU, power supply and I/O components shall be positioned freely within layout configuration of like modules with space between modules groups for additional 20% future spare modules.

**Appendix:5
Programmable Logic Controller (PLC)**

B. Provide power supply with following requirements:

1. Available input power source: 240-volt ac. 50 Hz.
2. Mounted near processor, but supporting free layout within configuration.

C. Provide Central Processing Unit (CPU) with following requirements:

1. Processor will be configured by integrator hired by Sub-developer.
2. Memory capacity: Available user memory: 750 Kbytes minimum.
3. Communication ports:
 - a. One Ethernet/IP.
 - b. One RS-232 Serial (DF1 or ASCII).
 - c. One Modbus RTU communication card
4. Include following additional features:
 - a. Lithium battery backed RAM user memory.
 - b. IEC 61131-3 compliant configuration software. Configuration software shall support relay ladders, structured text, function block diagram and sequential function chart programming.
 - c. Program CPU on-line or off-line.

2.04 LOCAL I/O MODULES:

A. In addition to I/O quantities required for each point type, provide 20% spare installed I/O points of each type.

B. Discrete Input:

1. Capacity: 16 channel.
2. Voltage: 24-volt dc, sink.
3. Grouping: 2 groups of 8 with common ground per group.

C. Discrete Output:

1. Capacity: 16 channel.
2. Voltage: 24-volt dc, sourced.
3. Grouping: 1 group of 16 with one set of supply and return points.

D. Analog Input:

1. Capacity: 8 channel.
2. Voltage/current: 24-volt dc.
3. Resolution: 16-bit.

Appendix:5 Programmable Logic Controller (PLC)

E. Analog Output:

1. Capacity: 8 channel.
2. Voltage/current: 24-volt dc.
3. Resolution: 16-bit.

2.05 LOCAL HUMAN MACHINE INTERFACE (HMI)

- A. Graphics display capable of accessing information from process automation controllers for local display and control.
- B. Graphic display shall be TFT/LCD color touch screen with Ethernet IP over copper media.

Interactive capability to allow operator to control I/O devices and acknowledge alarms from the graphics display. Operator shall be able to change modes between manual and automatic control and change device states between on and off, enter control setpoints, timer and counter settings, process variables, and loop information by 1 or 2 touch screen operations. The HMI shall be pre-programmed to provide a basic graphical display of the process. Real-time numeric display of process variables and alarm messages shall be available. All process control functions shall be accessible for the operator from the HMI. The application program shall be stored in "Non Volatile Memory".

- C. Security levels shall be accessible by user-defined passwords. Levels shall include engineering configuration of graphic displays and setting system parameters, operator control functions only, and process monitoring only.

- D. Mount graphic operator interface on control panels.

E. Processor:

1. Processors shall be capable of accessing field I/O points and registers available from programmable controller.
2. Failure of graphic operator interface processor shall in no way affect process automation controller's functions.
3. Multiple tasks shall be executed allowing concurrent program modification and real-time monitoring and control. Processor operating system shall execute commands entered by operator at same time it reads and updates input from field devices.
4. Processor shall have sufficient memory for storage, display, and execution of graphic pages with excess memory of 50% available for future programming needs, minimum 2MB.

**Appendix:5
Programmable Logic Controller (PLC)**

5. Control program and display configuration shall be retained by in flash memory to allow reloading after power failure.
 6. Processor shall perform continuous diagnostic scans to detect data communication status and programmable controller status. System shall recognize transmission format errors and either correct or request retransmission.
- F.** Display size: Nominal 15-inch diagonal.
- G.** Communication interface: Provide compatible communication interfacing between human machine interface components and programmable controller via Ethernet/IP protocol.
- H.** Accessories:
1. Supply system with necessary ventilating fans internal to console and cabinets.
 2. Provide manufacturer's standard utilities and startup software.
 3. Provide one registered copy of configuration software for Windows to be used by sub-developer.
- I.** HMI Manufacturer: To match or be compatible with PLC manufacturer.

2.06 PROGRAMMING DEVICE

- A.** Portable and capable of interfacing with programmable controllers furnished by this Contract.
- B.** Panel shall incorporate:
1. Alphanumeric keypad.
 2. Function keys shall allow user to construct a relay ladder diagram on CRT screen, and complete programming instructions.
- C.** Programming controls shall permit user to enter, edit, and delete logic and to monitor registers in decimal, hexadecimal, binary or ASCII and obtain On/Off status of discrete input/output points.

2.07 PROGRAM DOCUMENTATION AND REPORT GENERATION SYSTEM

- A.** Programmable controller manufacturer shall provide a program documentation package to perform following tasks:
1. Ladder diagram reports complete with ladder rungs; English description for every contact, bit, or word; organized logic sections with comment lines to identify logic function; rung comments to facilitate maintenance; and element cross references.
 2. Cross reference report: Sequential listing by element address of associated lines (or rungs).
 3. Input/output configuration summary: Table of entire I/O address range, showing which addresses are used by programmable controller program, which addresses have descriptions, and which are hardware I/O points.



Appendix:5 Programmable Logic Controller (PLC)

4. Contact address listing: Lists I/O addresses and their associated symbolic definitions.
 5. Record, load, and verification of program logic with program file on disk, and program difference listings.
- B.** Provide software to allow "off-line" programming using laptop/PC. Software shall document program as listed above. Provide required accessories to load program between programming panel and programmable controller.

2.08 PROGRAMMING

- A.** Configuration of control systems and their entry into microprocessor-based distributed system shall be responsibility of Sub-developer.
- B.** Entry and interaction of HMI/SCADA displays (overviews, summaries, loops, groups, graphics, etc.) with control units shall be responsibility of Sub-developer. Generic requirements shall be as defined below
- C.** PLC configuration:
1. PLC shall communicate with ETS energy meter calculator to monitor chilled water supply temperature, chilled water return temperature, chilled water flow, and calculated thermal energy usage at ETS.
 2. PLC shall communicate with the BAS to monitor the pump speed, pump status, start/stop, bypass valve status, PDT on the building chilled water system.
 3. PLC shall monitor the temperature of the chilled water supply temperature for the building chilled water system.
 4. Operator selects a setpoint for the building side chilled water supply temperature or building side return temperature or building side delta temperature
 - a. PLC modulates the control valve to control building side chilled water supply temperature or building side return temperature or building side delta temperature
 - b. Should the building side chilled water supply temperature/return temperature/delta temperature building side be above setpoint, the PLC shall move the control valve to a more open position.
 - c. Should the building side chilled water supply temperature/return temperature/delta temperature building side be below setpoint, the PLC shall move the control valve to a more closed position.
 5. PLC shall monitor the differential pressure across the chilled water supply and chilled water return for each ETS.
 6. UPS status (Main, Bypass, Trip, Battery low etc.) to be integrated with ETS PLC/HMI.
 7. All process variables shall be communicated from local PLC to district cooling plant control system utilizing standard open Ethernet TCP/IP communication protocol.

2.09 SOURCE QUALITY CONTROL

- A.** PLC and I/O equipment hardware shall be fully assembled, interconnected, and powered.

Appendix:5 Programmable Logic Controller (PLC)

- B.** Marafeq Qatar will witness sub-developer's tests as specified below.
1. Visual check will be performed to ensure correct equipment.
 2. Configuration and base level programs shall be loaded. Complete loop functional check shall be performed. Input signal shall be applied to each loop, and when applicable, output measured. Input/output values will be compared to display HMI/SCADA display values.
 3. Configuration displayed on HMI system will be verified.
- C.** Upon completion of satisfactory inspection, configuration and base level programs shall be recorded on machine-readable storage media and provided to Marafeq Qatar.

PART 3 EXECUTION

3.01 INSTALLATION

- A.** Install in accordance with manufacturer's recommendations and/or where designated by Marafeq Qatar.
- B.** Locate enclosures where designated by Marafeq Qatar.
- C.** Enclosure shall be positioned to allow doors to be fully opened for easy access to wiring and components.
- D.** Mount rigidly supported, level and plumb, and in such manner as to provide accessibility; protection from damage; isolation from heat, shock, and vibration; and freedom from interference with other equipment, piping, and electrical work. To avoid damage, equipment shall not be installed until adjacent heavy construction work has been completed
- E.** Manufacturer's recommendations referred to herein shall be as stated in manufacturer's instruction books and/or by manufacturer's service representative. Final interpretation of proper "installation requirements" will be by Marafeq Qatar.

SECTION C: PRIMARY PROCESS MEASURING DEVICES

PART 1 GENERAL

1.01 SECTION INCLUDES

- A.** Instruments and control equipment, flow sensing devices, pressure sensing devices, and PICV (**Appendix-4.2**).
- B.** Refer **Appendix 3.1** and **Appendix 3.2** for ETS P&ID for required Instrument selection.
- C.** Installation of instrumentation and control equipment including field transmitters, sensing elements, and miscellaneous devices.

1.02 INFORMATIONAL SUBMITTALS

- A.** Submit information relating to instrumentation and control devices referencing instrument tag number, as defined in ETS Guideline, on all submittal documents.
- B.** Pre-construction: Certified outline, installation, and wiring interconnection drawings for equipment and accessories provided. Wiring interconnection drawings shall define terminal numbers and functions for interface with other instruments and equipment.

1.03 ACTION SUBMITTALS

- A.** Pre-construction: Manufacturer's data or specification sheets for instrumentation and control devices showing design parameters, equipment catalog designations, calibration range, and clearly identifying options provided.

1.04 CLOSEOUT SUBMITTALS

- A.** Operation and maintenance manuals, for information only:
 - 1. Complete instruction manuals and parts lists covering installation, operation, wiring interconnections, and maintenance of equipment.
 - 2. Control loop diagrams for instrument and control devices wired to control system enclosures. Diagrams shall be in accordance with minimum requirements of ANSI/ISA S5.4. Control loop diagrams shall also include manufacturer, model number, and calibrated range; setpoint values for alarm and shutdown devices; equipment numbers for racks, panels, and junction boxes; exact location of device including column, row, and elevation; and control of solenoid valve fail-safe operation. Assign tag number oriented cable, wire, and tube numbers.
 - 3. Schematic drawings for motor or relay-based control logic. Show color of wire, all termination points, terminal numbers, cable and wire numbers. Assign cable and wire numbers for external panel wiring. Cable and wire numbers shall be tag number oriented.
- B.** Project record documents:

**Appendix:5
Programmable Logic Controller (PLC)**

1. "As built" control loop diagrams.
2. "As built" schematic drawings.
3. "As built" wiring diagrams.
4. "As built" circuit schedule.
5. "As built" control system architecture
6. "As built" communication (Modbus, Fiber optic etc.) drawings.
7. "As left" calibration report.

1.05 MAINTENANCE MATERIALS

- A.** Provide 2-year supply of spare parts as recommended by equipment manufacturer as part of initial procurement.

1.06 QUALITY ASSURANCE

- A.** Provide instruments from same manufacturer and of same model series when multiple units of same instrument are required.

- B.** Instruments, control devices and accessories shall be free of mercury and asbestos.

1.07 SITE CONDITIONS

- A.** Indoor applications:

1. Temperature: 4 to 50°C (40 to 122°F).
2. Humidity: 10 to 90%.

- B.** Outdoor applications:

1. Temperature: -1 to 55°C (30 to 130°F).
2. Humidity: 10 to 100%.

- C.** Electrical power source: 240 volts ac, 50 Hz.

- D.** Analog signals:

1. Voltage: 24-volt dc.
2. Range: 4 to 20 mA.
3. Load impedance: 0 - 750 ohms, minimum.

- E.** Discrete signals:

1. Voltage: 24-volt dc.
2. Contact type: Form C (1 NO, 1 NC), minimum.

Appendix:5 Programmable Logic Controller (PLC)

3. Rating: 2 amperes at 30-volts dc, minimum.

1.08 INSTRUMENT IDENTIFICATION

- A. Each instrument and control device shall have tag permanently attached with following information, as applicable:
1. Tag number.
 2. Manufacturer's name.
 3. Model number.
 4. Serial number.
 5. Operating range.
 6. Calibration setting/range.
 7. Power rating.

PART 2 PRODUCTS

2.01 GENERAL REQUIREMENTS

- A. Furnish insect proof screens on vents.
- B. Furnish new and unused instruments and control devices.
- C. Provide mounting accessories, etc. necessary to firmly mount and place device into service.

2.02 INSTRUMENTS

- A. Resistance Temperature Device (RTD) or Temperature Transmitter (TT):
1. Four-wire platinum nominal 500 ohm.
 2. Spring loaded with 15 mm threaded connection.
 3. 6 mm stainless steel sheath.
 4. Include Type 316 stainless steel reduced bore thermo well with 20 mm threaded process connection, 75 mm lag extension, 20 mm threaded sensor connection, with insertion length to allow tip to extend past to center of pipe diameter. Immersion length shall be suitably selected as per pipe diameter and manufacturer's recommendations.
 5. Each temperature sensor shall be provided with a transmitter, selected to match the sensor, from the same manufacturer.
 6. Except where specifically approved by the Owner, transmitter shall provide a 4 to 20 mA analogue output signal proportional to temperature measured.

Appendix:5 Programmable Logic Controller (PLC)

7. Accuracy shall be $\pm 0.1\%$ of full-scale reading and calibrated span.
8. Transmitter shall be mounted where indicated on approved piping schematic / design / shop drawings or instrument detail.
9. Mount transmitter integrally with sensor, pipe mounted or installed in a control panel, depending on the application, as per the Owner approved drawings.
10. Distance between sensor and transmitter shall not exceed manufacturer's recommendation.
11. Enclosure shall be SS 316, IP 67, NEMA 4X. Connection shall be screw terminals.
12. Power supply – 24 V DC loop powered.
13. Temperature range shall be -20 to 80 °C.

B. Pressure transmitter:

1. 4 to 20 mA dc output with local LCD indicator
2. Carbon steel process flanges and body.
3. 15 mm threaded process connections with 2-valve manifold and 50 mm pipe stand mounting hardware, unless otherwise indicated.
4. Calibrated span as required for the application.
5. Diaphragm of Type 316 stainless steel.
6. Accuracy: $\pm 0.1\%$ of calibrated span.
7. Design pressure: 1600 kPa maximum.
8. Design temperature: -20 to 80°C.
9. Over pressure rating shall be a minimum of 200 percent of operating pressure limit.
10. Transmitter shall be located where shown in the approved schematic / design / shop drawings, mounted integrally with sensor, pipe mounted or installed in control panel.
11. Distance between sensor and transmitter shall not exceed manufacturer's recommendation.
12. Wetted parts shall be minimum stainless steel 316, electronic enclosure shall be rated for NEMA 4X, IP 67.

C. Magnetic flow meter:

Design:

1. Shall be industrial type, inline electromagnetic type, bidirectional flow meter utilizing Faraday's law of electromagnetic induction to measure the volume flow rate of water

Appendix:5 Programmable Logic Controller (PLC)

2. Shall be suitable for the medium proposed to be handled by the flow meters.
3. Average flow rate shall be approximately in middle range of the flow meters.
4. Electrodes shall be removable type for ease of maintenance
5. Shall be with back lit, multi-line LCD display.
6. Body shall be carbon steel, flanges to ANSI 16.5 class150 or higher suitable for system design pressure, pipe to Stainless Steel 304 and electrodes of Stainless Steel 316.
7. Liner shall be EPDM or equivalent of approved manufacturers recommended.
8. Bidirectional flow rate measurement capability.
9. Accuracy shall be a minimum of 0.35% of flow rate over flow velocity range from 0.01 to 10 m/s.
10. Design Pressure: 16 Bars.
11. Test Pressure: 23 Bars.
12. Network chilled water temperature range: 5-14 °C, supply: 3-10 °C, return: 6-20 °C.
13. Ambient temperature: (-) 5°C to (+) 60°C.

Transmitter:

1. Output shall be 4 to 20 mA DC output signal proportional to the flow measured.
2. IP 67, NEMA 4X rated cast aluminum enclosure and shall be suitable for ambient environment of up to 60°C and 100% RH.
3. Shall be with self-diagnostic capability

D. Differential pressure transmitter:

1. Enclosure: IP 65 minimum
2. 4 to 20 mA dc output with local LCD indicator.
3. Measuring Pressure Range: 0 bar to 16 bars.
4. Stainless steel process flanges and body.
5. Process Connection: 1/2" SS 316L, all wetted parts shall be of SS 316L with mounting bracket for pipe stand mounting.
6. 50 mm pipe mounting hardware.
7. Power supply: Loop powered 24 volts dc.
8. Calibrated span as required for the application. Supplier shall provide external provision (Keypad) and HART for span and zero configuration

Appendix:5 Programmable Logic Controller (PLC)

9. Diaphragm of Type 316 stainless steel.
10. Accuracy: +/-0.1% of calibrated span.
11. Stability: +/-0.25% of upper range for minimum 5 years.
12. Design pressure: 16 bar maximum.
13. Damping : Adjustable damping with minimum of 0.2 seconds
14. Over pressure limit: Twice the operating range.
15. Design temperature: -20 to 80°C.
16. 1/2" threaded process connections with 3-way valve manifold and 50 mm pipe stand mounting hardware, unless otherwise indicated.

2.03 INSTRUMENT WIRING

A. Wire and cable:

1. Analog signal cable:
 - a. Configuration: Twisted pair, shielded, and jacketed.
 - b. Insulation: 300-volt, 15 mil, 90°C, PVC, color-coded to permit identification of each conductor.
 - c. Conductors: 1.0 square mm, 7 strand copper, Class B.
 - d. Shield: Tinned copper braid providing 100% coverage against noise together with 0.05 mm² stranded tinned drain wire.
2. Power wire:
 - a. Rating: 600-volt, 90°C, PVC insulation/jacket.
 - b. Conductors: 2.5 square mm stranded copper.
3. Discrete signal wire:
 - a. Rating: 600-volt, 90°C, PVC insulation/jacket.
 - b. Conductors: 1.5 square mm, stranded copper.

B. Conductors shall be continuous between devices. Splices are not acceptable.

C. Conductors shall be terminated with pressure type, pre-insulated, flanged, slotted, tongue, indenter lugs. Soldered terminators are not acceptable.

2.04 CABLE IDENTIFICATION

A. Identify each cable with plastic tags permanently affixed to cable.

1. Attach tags to each cable at each termination and wherever cable is accessible in junction or pull boxes.
2. Provide tags with printer-printed circuit number.

Appendix:5 Programmable Logic Controller (PLC)

- B. Provide 3-phase power cables with tag with printer-printed cable number affixed to each phase conductor.
- C. Tag colors:
 - 1. Power cables: Red tags.
 - 2. Analog and discrete signal cables: Yellow tags.
- D. Cable tags shall be produced utilizing Raychem TMS cable identification system with TMS permatizer, or equal.

PART 3 EXECUTION

3.01 INSTALLATION - GENERAL

- A. Install instrument and control devices in accordance with manufacturer's recommendations and/or where approved by Marafeq Qatar.
- B. Mount instruments to be rigidly supported, level and plumb, and in such a manner as to provide accessibility; protection from damage; isolation from heat, shock and vibration; and freedom from interference with other equipment, piping, and electrical work.
- C. To avoid damage, do not install instruments until heavy construction work adjacent to instruments has been completed.
- D. Manufacturer's recommendations referred to herein shall be as stated in manufacturer's installation manual and/or by manufacturer's service representative. Final interpretation of "installation requirements" will be by Marafeq Qatar.

3.02 INSTRUMENT EQUIPMENT MOUNTING

- A. Mount instrumentation equipment to building steel, concrete floors, or walls using pipe mounting stands or field-fabricated mounting brackets.
 - 1. Secure instrumentation equipment mounting bracket to building steel by welding, and to concrete or masonry building structure by expansion-type anchors. Do not mount instrumentation equipment to exterior removable panels.
 - 2. If vibration-free location is not available for instrument mounting, appropriate vibration shock mounting shall be provided by use of rubber grommets or other vibration dampeners designed for vibration absorption subject to Marafeq Qatar review.
 - 3. Install instrumentation mounted outdoors within sun protection enclosures. Enclosure opening shall face north or east, insofar as practicable.
 - 4. Instrumentation mounted outdoors shall be housed in insulated/heated housings to maintain operational temperature limits.
- B. Instrument accessibility: Following general rules shall be adhered to, unless limited by other requirements in design of system.



Appendix:5 Programmable Logic Controller (PLC)

1. Locate instrument process connections for maximum convenience in operation and servicing of instrument. Orient connections so instruments or piping will not obstruct aisles, platforms, or ladders. Transmitters shall be visible and accessible for maintenance.
2. Install field-mounted instruments so they are accessible from grade, platform, or permanent ladder. Instruments requiring adjustment or inspection shall be accessible for servicing from grade, walkway, platform, or permanent ladder.
3. Locate remote instruments and control devices (devices not located in or on process lines) at nominal height of 1,370 mm (4-1/2 feet) above finished floor, grade, or platform. Provide instrument racks for location in which 3 or more instruments or control devices are located within close proximity of each other.
4. Control valves shall be accessible from grade or platforms. Use manufacturer's recommended clearance distances.
5. Mount local indicators, recorders, and controllers so they are readable, controllable, and serviceable from grade or platforms.

3.03 CLEANING

- A. Before assembly or erection, thoroughly clean instruments of temporary protective coatings and foreign materials.
- B. After erection of equipment, clean external surfaces of oil, grease, dirt, or other foreign material.

BULK (ENERGY) METER GUIDELINE

1.01 GENERAL

This document presents technical and installation guidelines for district cooling bulk-meters located in the building Energy Transfer Stations (ETSs). The bulk-meter measures the cooling energy taken by the ETS, and consists of a flow meter, supply and return temperature sensors, energy calculator, and un-interrupted power supply.

Based on the temperature sensors, the energy calculator automatically calculates water density and enthalpy. From the flow meter, volume flow is converted into mass flow and used to calculate thermal energy.

The bulk-meter shall be installed on the front door of PLC panel or inside the IP rated lockable cabinet enclosure with window glass as per the site conditions and integrated with the PLC system. Refer **Appendix -5** for the PLC detailed requirement.

Sub-developer shall follow manufacturer's guidelines for installation and wiring

Marafeq's personnel shall have unconditional access to the bulk-meter 24/7.

1.02 TECHNICAL REQUIREMENTS

- A. Bulk-meter shall be equipped with its necessary flow meter and temperature sensors and shall be provided for billing computation. Refer **Appendix-5** for temperature (RTD) sensors, flow meter specification.
- B. Sensor cables shall be long enough to connect the sensors to the bulk-meter without splices or joints.
- C. Supply and return temperature shall be measured via resistance temperature devices (RTDs), 4-wire, Pt 500, and shall use matched pairs, class A to IEC 751 standard.
- D. Flow meter shall be electromagnetic flow model. Flow meter shall be provided with appropriate meter run (up and down stream straight lengths of pipe).
- E. Flow meter and temperature sensors shall have pulse and analog 4-20 mA outputs to the bulk-meter.
- F. Bulk-meter shall comply with custody transfer application requirements and EN 1434, Class 1. Certification shall be provided.
- G. Bulk-meter shall communicate with the PLC via Modbus.
- H. Bulk-meter shall have large back-lit LC display with color change in the event of an error.
- I. Bulk-meter shall have quick and safe commissioning with application-guided operation (Quick Setup)
- J. Bulk-meter and its associated instruments shall be from the same supplier.
- K. Bulk-meter time/date stamping and able to synchronize with network via ETS PLC.
- L. Bulk-meter shall be capable of storing at least 36 months data; EEPROM historical memory storage.



Appendix:6 Bulk (Energy) Meter Guideline

- M. Bulk-meter shall have internal real time clock with battery backup which shall able to synchronize with ETS PLC.
- N. Protection class of bulk-meter shall be IP 54 and for flow sensors shall be IP65
- O. ETS bulk-meter schematic diagram is illustrated in Figure 1.

1.03 DISPLAY

Minimum following values shall be displayed with engineering units. The meter display shall have the switchover option to the different engineering units so as to measure correct reading with minimum two decimal digits. The name and symbol of unit in which displayed value is given shall be indicated adjacent of the same value:

- A. Power: To be measured in Ton, MW, KW and Watts.
- B. Energy: To be measured in Ton-Hr., MW-Hr., KW-Hr. and Watts-Hr.
- C. Flow : To be measured in GPM, LPS and m³/Hr
- D. Volume: To be measured in Gallon, Litre, m³
- E. Temperature: To be measured in °C and °F

1.04 SERVICE CONDITIONS

- A. Design Pressure : 16 Bars
- B. Test Pressure: 23 Bars
- C. Network Temperature range: 5-14 °C, Supply: 3-10 °C, Return: 6-20 °C
- D. Ambient temperature: (-) 5°C to (+) 60°C

1.05 SERVICE BACK-UP

- A. The sub-developer shall arrange training for Marafiq's operation & maintenance staff by the manufacturer's experts.
- B. Sub-developer shall provide manufacturer's contact detail locally in Qatar authorized for sales and service. Each manufacturer shall confirm they can provide service technicians with 24 hours' notice.
- E. Provide contact details for authorized service center in Qatar for repair, overhaul, or after sales service.
- F. Manufacturer shall confirm essential spare parts are available locally in Qatar.
- G. Manufacturer shall confirm he has an established QA/QC program.
- H. Warranty: Minimum 3 years or as per contract documents, whichever is higher.



Appendix:6 Bulk (Energy) Meter Guideline

1.06 HARDWARE AND SOFTWARE RELEASES

- A. Provide hardware to manufacturer's latest revision level. Provide hardware release upgrades, on overlapped exchange basis, as issued by manufacturer, from date of initial equipment shipment through end of warranty period of Contract.
- B. Provide manufacturer's system software upgrades as issued, from date of initial equipment through end of warranty period of Contract. Display software revision level on main menus.

1.07 RESET FUNCTIONS AND HISTORICAL DATA RECORDING :

- A. The reset shall be carried through the following way:
 - 1. Manual, by pressing reset button
- B. On every reset all registered data along with date and time of reset shall be transferred to historical register storage

1.08 INSTALLATION

The bulk-meter shall be installed on the front door of PLC panel or inside the IP rated lockable cabinet enclosure with window glass as per the site conditions and integrated with the PLC system. Refer **Appendix -5** for the PLC detailed requirement.

1.09 SECURITY AND REDUNDANCY

The following security and redundancy feature shall be provided:

- A. Hot swappable and redundant power supply

1.10 DELIVERY, HANDLING, AND STORAGE

- A. Delivery, storage, and protection shall be in accordance with manufacturer's recommended procedures.
- B. Accept products on site in factory containers and verify any damage.
- C. Store products in clean, dry area. Maintain temperature in accordance with NEMA ICS 1.

1.11 WARRANTY

- A. Warranty shall not begin until final acceptance of system by Owner.
- B. Specified availability shall be maintained throughout warranty period. Failure to achieve specified availability may, at Owner option, result in extension of warranty period until specified performance has been met for continuous period equivalent to warranty period.

1.12 ACCEPTABLE MANUFACTURER LIST:

Technical details shall be submitted for Marafeq's approval.

- 1. Endress+ Hauser
- 2. Contrec
- 3. Kamstrup

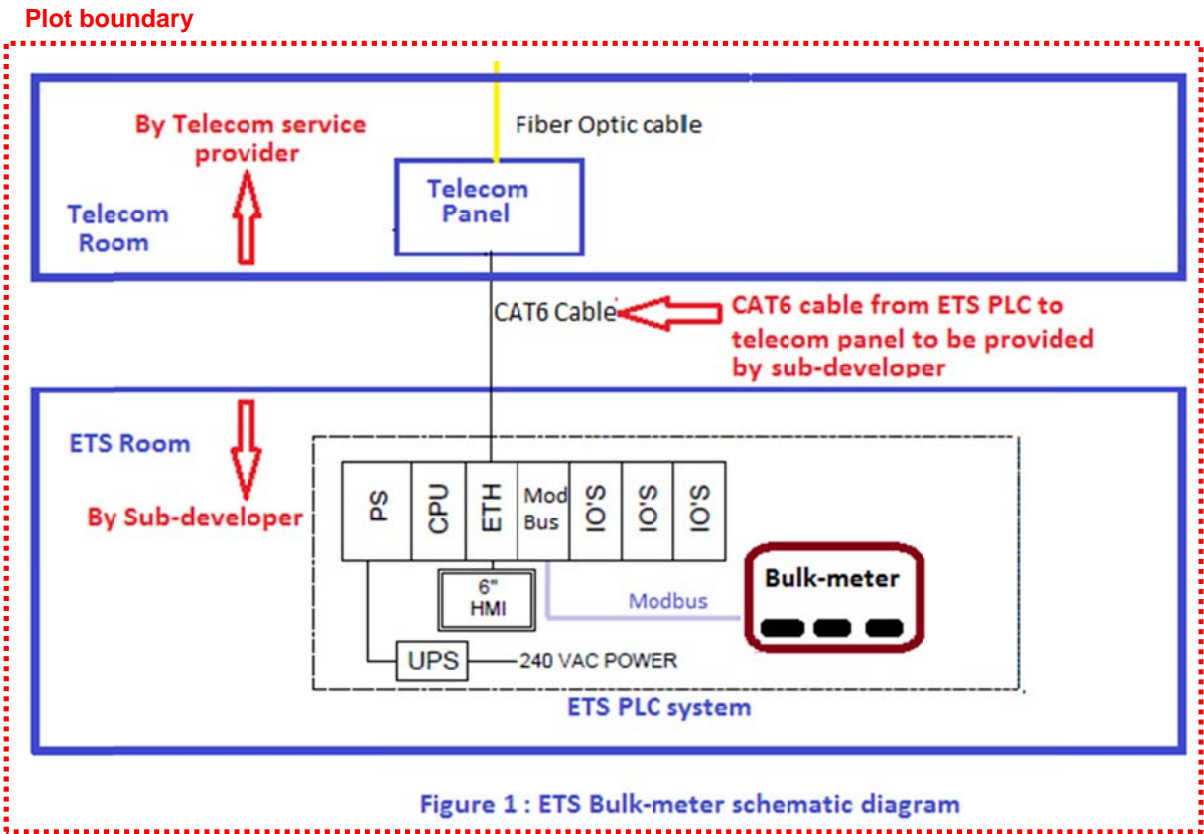



Appendix:7.1

Marafeq Technical Requirements for the connection of ETS(s) to the District Cooling System

Compliance Statement: Method Statement for Installation, Testing and Commissioning of equipment inside ETS (Primary side)

S. No.	Description	Status
A	Documentation requirements	
1	<p>The following documents shall be submitted to Marafeq for review and approval. Upon approval contractor may proceed for commissioning with due notice to Marafeq where applicable:</p> <ul style="list-style-type: none"> ➤ Compliance sheet for installation, testing and commissioning (this document) ➤ Vendor approved installation, testing and commissioning procedures for each material mentioned in section-B of this document. ➤ Installation, testing and commissioning template sheet 	
B	Material	
1	<ul style="list-style-type: none"> ➤ Heat exchanger ➤ Pre-insulated pipe ➤ PICV (Pressure Independent Control Valve) ➤ Strainer ➤ Ball valve ➤ Instruments (Pressure gauge, pressure differential transmitter, temperature gauge, temperature transmitter, flow meter, Energy meter) ➤ PLC 	
Installation/Testing/Commissioning/Calibration		
C	Heat Exchanger	
1	Ensure that the material is received, inspected and stored in good condition	
2	Ensure that material shall be installed as per manufacturer installation recommendation/procedure	
3	Ensure that the material shall be tested/ commissioned/calibrated as per manufacturer recommendation/procedure	
4	Ensure that the installation, testing/commissioning/calibration record sheet duly filled shall be available for Marafeq signature/acceptance	
D	Pre-insulated pipe	
1	Ensure that the material is received, inspected and stored in good condition	
2	Ensure that material shall be installed as per manufacturer installation recommendation/procedure	
3	Ensure that the material shall be tested/ commissioned/calibrated as per manufacturer recommendation/procedure	
4	Ensure that the installation, testing/commissioning/calibration record sheet duly filled shall be available for Marafeq signature/acceptance	
E	PICV	
1	Ensure that the material is received, inspected and stored in good condition	



Appendix:7.1

S. No.	Description	Status
2	Ensure that material shall be installed as per manufacturer installation recommendation/procedure	
3	Ensure that the material shall be tested/ commissioned/calibrated as per manufacturer recommendation/procedure	
4	Ensure that the installation, testing/commissioning/calibration record sheet duly filled shall be available for Marafeq signature/acceptance	
F	Strainer	
1	Ensure that the material is received, inspected and stored in good condition	
2	Ensure that material shall be installed as per manufacturer installation recommendation/procedure	
3	Ensure that the material shall be tested/ commissioned/calibrated as per manufacturer recommendation/procedure	
4	Ensure that the installation, testing/commissioning/calibration record sheet duly filled shall be available for Marafeq signature/acceptance	
G	Ball Valve	
1	Ensure that the material is received, inspected and stored in good condition	
2	Ensure that material shall be installed as per manufacturer installation recommendation/procedure	
3	Ensure that the material shall be tested/ commissioned/calibrated as per manufacturer recommendation/procedure	
4	Ensure that the installation, testing/commissioning/calibration record sheet duly filled shall be available for Marafeq signature/acceptance	
H	Instruments (Pressure gauge, pressure differential transmitter, temperature gauge, temperature transmitter, flow meter, relief valve)	
1	Ensure that the material is received, inspected and stored in good condition	
2	Ensure that material shall be installed as per manufacturer installation recommendation/procedure	
3	Ensure that the material shall be tested/ commissioned/calibrated as per manufacturer recommendation/procedure	
4	Ensure that the installation, testing/commissioning/calibration record sheet duly filled shall be available for Marafeq signature/acceptance	

Signature and Stamp of Consultant

Date:

Signature and Stamp of Contractor/Supplier

Date:



Appendix:7.2

Marafeq Technical Requirements for the connection of ETS(s) to the District Cooling System

Compliance Statement: Method Statement for Hydro static test (Primary side)

S. No.	Description	Status
A	Documentation requirements	
1	<p>The following documents shall be submitted to Marafeq for review and approval. Upon approval contractor may proceed for flushing with due notice to Marafeq for witness of the test:</p> <ul style="list-style-type: none"> ➤ Compliance sheet for hydro static test (this document) ➤ Marafeq approved ETS P&ID ➤ Building services consultant approved ETS section drawing showing all equipment, piping and instruments inside ETS room ➤ Method statement for hydrostatic test, including risk assessment program ➤ All necessary local authorities approval pertaining to Hydro testing ➤ Hydro static test record sheet template 	
B	System Preparation	
1	Installation inspection shall be completed based on Marafeq approved drawing/ procedures, and all outstanding snags shall be closed prior to the start of hydro test	
2	All instruments used during hydro test shall be calibrated and the calibration certificates shall be available for Marafeq information.	
3	Ensure all valves are opened during hydro test	
4	Pressure gauge shall be installed at the lowest and highest point. Temperature gauge shall be installed near to pressure gauge.	
5	Safety relief valve shall be installed at the highest point of which shall be set at 105% of the test pressure, to prevent the over pressurization of the lines	
6	Ensure all necessary HSE arrangements for the successful completion of hydro testing activities	
C	Hydro test procedure	
1	Fill-up the pipe system with potable water to be tested	
2	Ensure that air is released completely	
3	Gradually pump up pressure to the level stated below Test pressure, 23 bar (2300 kPa)	
4	Pressure holding time shall be 6 hours, before the inspection of joints	
5	Pressure and temperature shall be recorded every hour in an approved hydro test record sheet	
D	Hydro test acceptance	
1	No visible leak shall be notice during hydro test period, which is the passing criteria for the hydro test	
2	Once the pressure test is successfully completed, depressurize the system gradually	
3	Pressure and temperature readings which was recorded during the hydro test shall be submitted to Marafeq Qatar for the approval/acceptance of hydro test	

Signature and Stamp of Consultant

Date:

Signature and Stamp of Contractor/Supplier

Date:



Appendix:7.3

Marafeq Technical Requirements for the connection of ETS(s) to the District Cooling System

Compliance Statement: Method Statement for Flushing/Pipe conditioning (Primary side)

S. No.	Description	Status
A	Documentation requirements	
1	<p>The following documents shall be submitted to Marafeq for review and approval. Upon approval contractor may proceed for flushing with due notice to Marafeq for witness of the test:</p> <ul style="list-style-type: none"> ➤ Compliance sheet for flushing (this document) ➤ Method of statement for flushing/pipe conditioning including risk assessment program. (Application guide for the method of statement shall be BSRIA application guide AC 1/2001.1) ➤ All necessary local authorities approval pertaining to flushing/pipe conditioning activities ➤ Flushing/pipe conditioning record sheet template for each stage 	
B	System Preparation	
1	All equipment, bypasses, drain and vent shall be installed as per the approved method statement for flushing	
2	Ensure that all utilities/consumables (including but not limited to potable water, fuel, chemicals, filters etc.) are available at site to proceed for flushing	
3	Critical drain points shall be connected to the nearest drain pit to facilitate emergency draining if situation demands	
4	Flow meter shall be available at site to monitor the velocity of flushing activity in line with approved method of statement	
5	Pressure gauge shall be installed at the lowest and highest point. Temperature gauge shall be installed near to pressure gauge.	
6	All instruments used during flushing shall be calibrated and the calibration certificates shall be available for Marafeq information.	
7	Water treatment specialist shall be available at site to monitor the progress of flushing activities	
8	Ensure all necessary HSE arrangements for the successful completion of flushing/pipe conditioning activities	
9	Marafeq will inspect the system readiness, and accordingly will release the "request to proceed" submitted by the flushing contractor	
C	Flushing Procedure	
1	<p>The whole flushing/pipe conditioning process generally falls under the following stages:</p> <ul style="list-style-type: none"> ➤ Flushing ➤ Chemical cleaning ➤ Passivation 	
2	Flushing shall start within 48 hours of the hydrostatic test; otherwise preventive measures shall be taken to avoid corrosion.	
3	Top up the system completely with potable water and release the air	
4	Start the pump at low speed and vent the air out of the system completely	
5	Gradually increase the speed of the pump to meet with sufficient flushing velocity	



Appendix:7.3

S. No.	Description	Status																		
6	Follow the procedure as mentioned in the approved method of statement for flushing/pipe conditioning																			
7	After final passivation is achieved , the system shall be preserved in line with passivation water quality																			
D	Flushing /Pipe conditioning acceptance																			
1	Each stage of flushing/pipe conditioning shall be approved by Marafeq before proceeding to next stage																			
	Sampling at each stage shall be witnessed by Marafeq																			
2	Final passivation water quality shall be as per the below chart: <table border="1" data-bbox="284 629 1082 994"><thead><tr><th>Final water parameters</th><th>Acceptance limit</th></tr></thead><tbody><tr><td>pH</td><td>9 to 10.5</td></tr><tr><td>Total Iron (mg/L)</td><td><1.0</td></tr><tr><td>Nitrite (NO₂) (ppm)</td><td>>800</td></tr><tr><td>Conductivity (μS/cm)</td><td><3000</td></tr><tr><td>Suspended Solids (mg/L)</td><td><10</td></tr><tr><td>Total Dissolved Solids (mg/L)</td><td><2000</td></tr><tr><td>Total Hardness (ppm)</td><td><100</td></tr><tr><td>M-Alkalinity (ppm)</td><td><250</td></tr></tbody></table>	Final water parameters	Acceptance limit	pH	9 to 10.5	Total Iron (mg/L)	<1.0	Nitrite (NO ₂) (ppm)	>800	Conductivity (μS/cm)	<3000	Suspended Solids (mg/L)	<10	Total Dissolved Solids (mg/L)	<2000	Total Hardness (ppm)	<100	M-Alkalinity (ppm)	<250	
Final water parameters	Acceptance limit																			
pH	9 to 10.5																			
Total Iron (mg/L)	<1.0																			
Nitrite (NO ₂) (ppm)	>800																			
Conductivity (μS/cm)	<3000																			
Suspended Solids (mg/L)	<10																			
Total Dissolved Solids (mg/L)	<2000																			
Total Hardness (ppm)	<100																			
M-Alkalinity (ppm)	<250																			
3	Water analysis result based on the above parameters shall be recorded in passivation record sheet and shall be submitted to Marafeq for final acceptance, along with the water treatment specialist water analysis report																			
4	Tie in with the other adjoining system shall be executed (where ever applicable)																			

Signature and Stamp of Consultant

Date:

Signature and Stamp of Contractor/Supplier

Date: